

PARTS CATALOGUE

TZ250 (5KE4) JAPAN

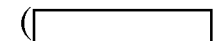

1B5KE-010E1



TZ250
PARTS CATALOGUE
©2005 by Yamaha Motor Co., Ltd.
1st edition, February 2005
All rights reserved.
Any reprinting or unauthorized use
without the written permission of
Yamaha Motor Co., Ltd.
is expressly prohibited.
Printed in Japan.

FOREWORD

This Parts Catalogue is related to the parts for the model(s) on the cover page. When you are ordering replacement parts, please refer to this Parts Catalogue and quote both part numbers and part names correctly.

1. Modifications or additions which have been made after the issue of the Parts Catalogue will be announced in the Parts News.

It is advisable that you make the necessary corrections to the Parts Catalogue according to the Parts News.

2. Abbreviations

The following abbreviations are used in this Parts Catalogue.

“UR” Use specified parts number.

“UN” Use as many as needed.

“AP” Alternate Parts

“LM” Locally Made (Parts need to be ordered locally)

“F#” Frame No. (Applicable machine No.)

“O/S” Over Size

3. The number of components for assembly

- Parts, which are to be supplied in an assembly, are listed with a dot (.) in front of the part name as shown below.
- The numeral appearing to the right of each component part indicates the quantity of parts for each assembly unit.

PART NO.	DESCRIPTION	Q'TY	REMARKS
2F5-83310-60	FRONT FLASHER LIGHT ASSY	2	
115-83311-60	.BULB (6V-18W)	1	

4. Applicable colours of graphics are represented in the “REMARKS” as shown below.

PART NO.	DESCRIPTION	Q'TY	REMARKS
2N4-24110-00-X5	FUEL TANK COMP.	2	MXR
3J1-24240-10	.GRAPHIC, FUEL TANK	1	FOR MXR

5. Note that the illustrations for reference in finding parts numbers are not to be used for assembling. When assembling, please use the applicable service manual.

6. The asterisk (*) before a reference number indicates modified items after the first edition.

CONTENTS

ENGINE

CYLINDER HEAD	1
CRANKSHAFT. PISTON	3
COUNTER SHAFT	4
WATER PUMP	5
RADIATOR. HOSE	6
OIL PUMP	7
INTAKE	8
CARBURETOR	10
EXHAUST	12
CRANKCASE	13
CLUTCH	14
TRANSMISSION	16
SHIFT CAM. FORK	18
SHIFT SHAFT	19

CHASSIS

FRAME	20
REAR ARM	22
REAR SUSPENSION	23
STEERING	24
FRONT FORK	25
FUEL TANK	27
SEAT	29
FRONT WHEEL	30
FRONT BRAKE CALIPER	31
REAR WHEEL	32
REAR BRAKE CALIPER	34
STEERING HANDLE. CABLE	35
FRONT MASTER CYLINDER	36
STAND. FOOTREST	38
COWLING 1	40
GENERATOR	42
METER	43
HANDLE SWITCH. LEVER	44
ELECTRICAL 1	45

INDEX

NUMERICAL INDEX	46
-----------------------	----

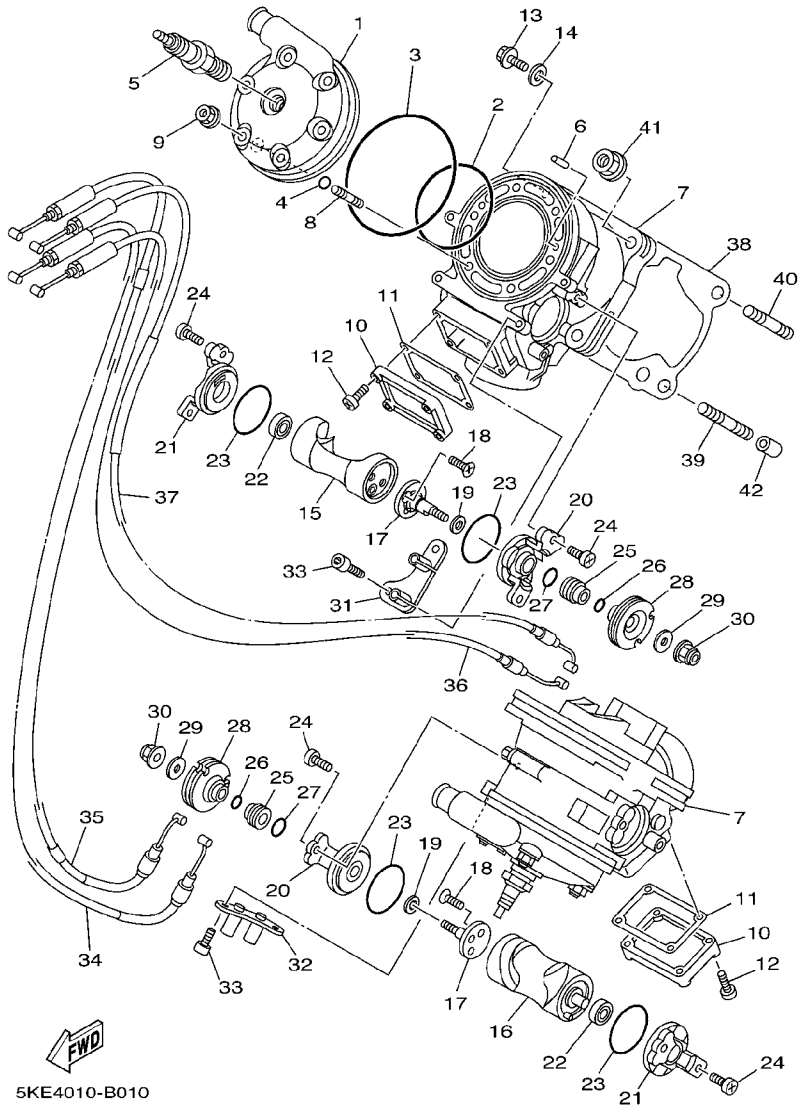

FIG. 1 CYLINDER HEAD

REF NO.	PART NO.	DESCRIPTION	5KE4			REMARKS
1	5KE-11111-10	HEAD, CYLINDER 1	2			
2	93210-63556	O-RING	2			
3	93210-88696	O-RING	2			
4	93210-06001	O-RING	12			
5	94709-00374	PLUG, SPARK (R6179A-105P)	2			NGK
6	93604-08071	PIN, DOWEL	4			
7	5KE-11311-10	CYLINDER 1	2			
8	90116-06466	BOLT, STUD	12			
9	95707-06500	NUT, FLANGE	12			
10	5KE-1131M-00	COVER	2			
11	5KE-11354-00	GASKET	2			
12	98907-05020	SCREW, BIND	8			
13	95827-06010	BOLT, FLANGE	2			
14	90430-06166	GASKET	2			
15	5KE-1131D-10	VALVE ASSY	1			
16	5KE-1132D-10	VALVE ASSY 2	1			
17	5KE-1134E-00	SHAFT, PULLEY	2			
18	90149-05245	SCREW	4			
19	90201-08027	WASHER, PLATE (T=0.8)	2			UR
	90201-08028	WASHER, PLATE (T=0.9)	2			UR
	90201-08029	WASHER, PLATE (T=1.0)	2			UR
	90201-08030	WASHER, PLATE (T=1.1)	2			UR
	90201-08032	WASHER, PLATE (T=1.2)	2			UR
	90201-08033	WASHER, PLATE (T=1.3)	2			UR
20	5KE-1131X-00	HOLDER ASSY. ,1	2			
21	5KE-1131F-00	HOLDER 2	2			
22	93300-68821	BEARING	2			

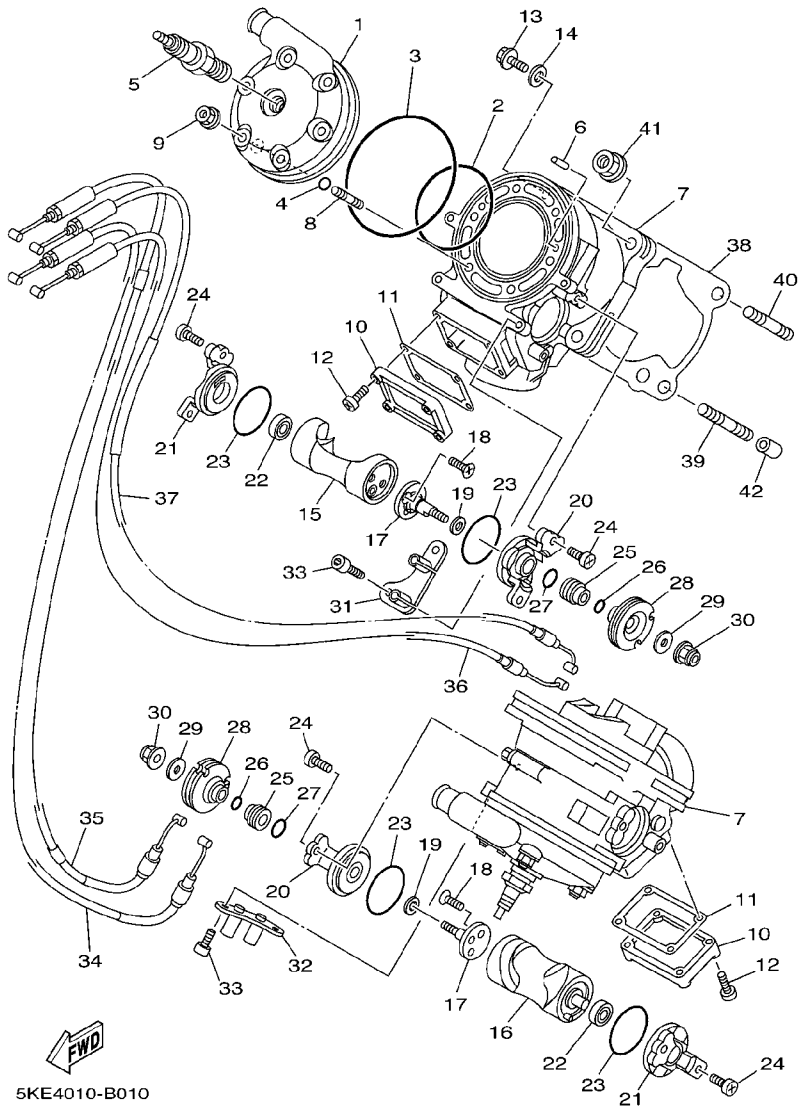

FIG. 1 CYLINDER HEAD

REF NO.	PART NO.	DESCRIPTION	5KE4				REMARKS
23	93210-34001	O-RING	4				
24	98907-05012	SCREW, BIND	8				
25	5KE-1131W-00	SPACER, 1	2				
26	93210-07435	O-RING	2				
27	93210-11453	O-RING	2				
28	5KE-1132E-00	PULLEY 1	2				
29	92907-06200	WASHER	2				
30	95707-06500	NUT, FLANGE	2				
31	5KE-11932-00	SETTER, WIRE	1				
32	5KE-11932-10	SETTER, WIRE	1				
33	91317-05010	BOLT	4				
34	5KE-1133E-00	CABLE, PULLEY 1	1				
35	4TW-1133F-00	CABLE, PULLEY 2	1				OPEN
36	4TW-1133G-01	CABLE, PULLEY 3	1				
37	5KE-1133H-00	CABLE, PULLEY 4	1				
38	5KE-11351-50	GASKET, CYLINDER (T=0.5)	2				STD
	5KE-11351-20	GASKET, CYLINDER (T=0.2)	2				AP
	5KE-11351-30	GASKET, CYLINDER (T=0.3)	2				AP
	5KE-11351-40	GASKET, CYLINDER (T=0.38)	2				AP
39	90116-08104	BOLT, STUD	4				
40	90116-08564	BOLT, STUD	4				
41	95707-08500	NUT, FLANGE	8				
42	99510-10114	PIN, DOWEL	4				

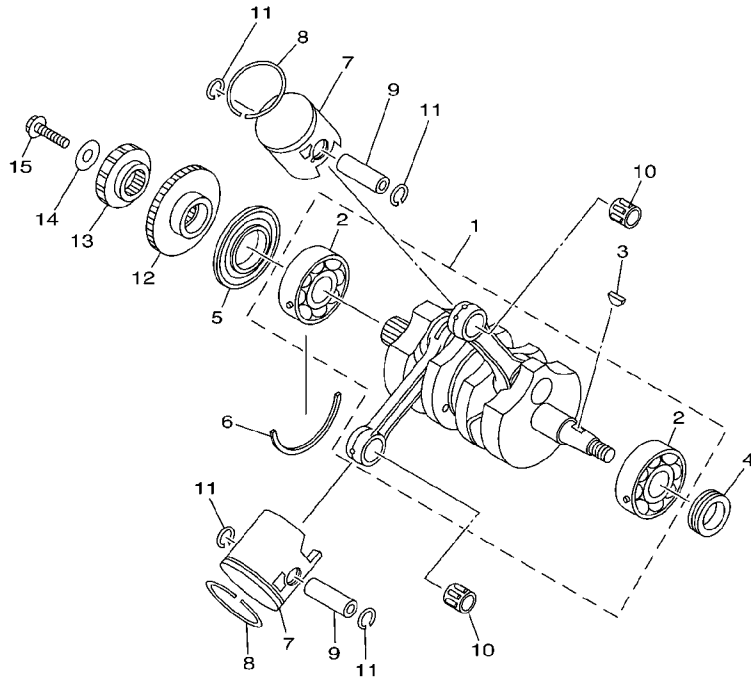
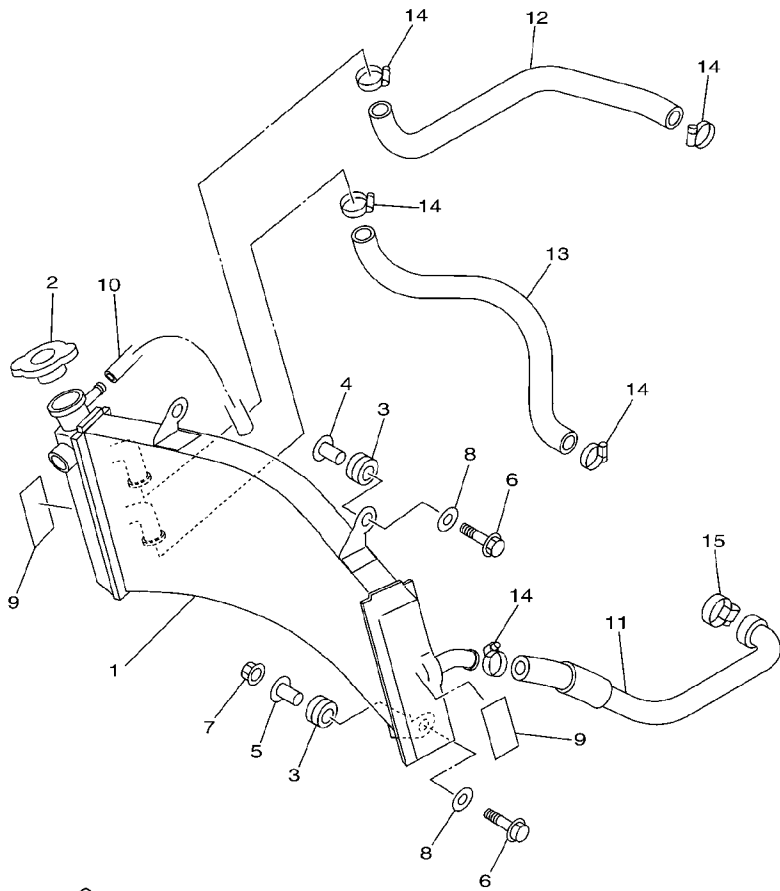

FIG. 2 CRANKSHAFT, PISTON

REF NO.	PART NO.	DESCRIPTION	5KE4				REMARKS
1	5KE-11400-10	CRANKSHAFT ASSY	1				
2	93306-30572	BEARING	2				
3	90280-04001	KEY, WOODRUFF	1				
4	93102-25438	OIL SEAL	1				
5	93102-35030	OIL SEAL	1				
6	278-17424-01	CIRCLIP 1	1				
7	5KE-11631-20-A0	PISTON (STD)	2				UR RED
	5KE-11631-20-B0	PISTON (STD)	2				UR ORENGE
	5KE-11631-20-C0	PISTON (STD)	2				UR GREEN
8	4JT-11611-11	RING, PISTON	2				
9	4XM-11633-01	PIN, PISTON	2				
10	93310-31510	BEARING	2				
11	93450-16068	CIRCLIP	4				
12	5KE-11536-00	GEAR, DRIVE	1				
13	5KE-16111-00	GEAR, PRIMARY DRIVE	1				
14	90201-10144	WASHER, PLATE	1				
15	90105-10445	BOLT, FLANGE	1				



5KE3100-A020



5KE1100-0050

FIG. 5 RADIATOR. HOSE

REF NO.	PART NO.	DESCRIPTION	5KE4				REMARKS
1	4TW-12461-01	RADIATOR ASSY	1				
2	22W-12462-00	CAP, RADIATOR	1				
3	90480-15363	GROMMET	3				
4	90387-066N1	COLLAR	2				
5	90387-063E6	COLLAR	1				
6	95027-06030	BOLT, FLANGE	3				
7	95607-06200	NUT, SELF U-FLANGE	1				
8	90201-06571	WASHER, PLATE	3				
9	3YL-12232-00	DAMPER	2				
10	90445-09304	HOSE (L310)	1				
11	5KE-12482-00	PIPE 2	1				
12	5KE-12483-00	PIPE 3	1				
13	5KE-12484-00	PIPE 4	1				
14	90460-20190	CLAMP, HOSE	5				
15	90450-40009	HOSE CLAMP ASSY	1				

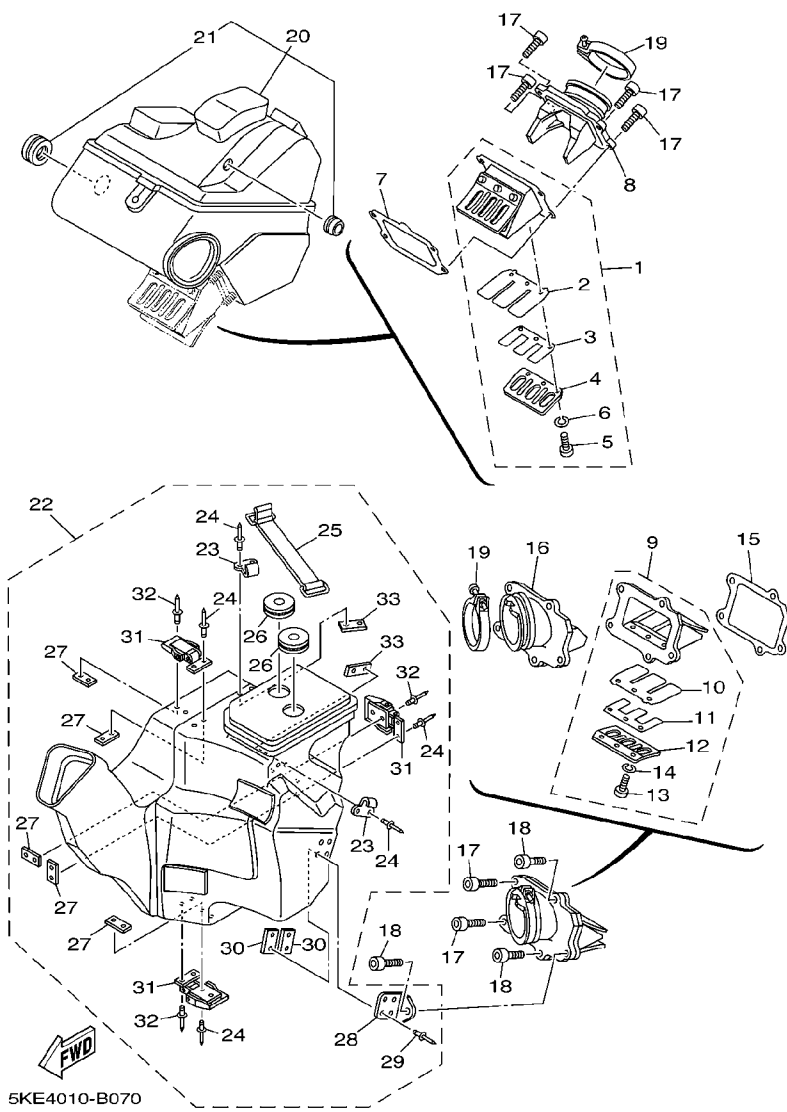

FIG. 7 INTAKE

REF NO.	PART NO.	DESCRIPTION	5KE4				REMARKS
1	5KE-13610-00	REED VALVE ASSY	1				
2	3XV-13613-01	.REED, VALVE	2				
3	2KM-13614-00	.REED, VALVE 2	2				
4	3YL-13617-00	.STOPPER, REED VALVE 2	2				
5	98507-03006	.SCREW, PAN HEAD	6				
6	92907-03100	.WASHER, SPRING	6				
7	5KE-13621-01	GASKET, VALVE SEAT	1				
8	5KE-13555-00	MANIFOLD, INTAKE	1				
9	5KE-13620-00	REED VALVE ASSY	1				
10	3XV-13613-01	.REED, VALVE	2				
11	2KM-13614-00	.REED, VALVE 2	2				
12	3YL-13617-00	.STOPPER, REED VALVE 2	2				
13	98507-03006	.SCREW, PAN HEAD	6				
14	92907-03100	.WASHER, SPRING	6				
15	5KE-13622-00	GASKET, VALVE SEAT	1				
16	5KE-13565-00	JOINT, CARBURETOR	1				
17	91317-06025	BOLT	6				
18	91314-06020	BOLT	3				
19	90460-52210	CLAMP, HOSE	2				
20	5KE-2160A-02	BOX COMP.	1				
21	90480-25482	.GROMMET	1				
22	5KE-21240-10	BOX COMP.	1				
23	4TW-2175R-00	.HOOK, BAND	2				
24	90267-30189	.RIVET, BLIND	10				
25	18G-82131-00	.BAND, BATTERY	1				
26	90480-25482	.GROMMET	2				
27	4TW-2175L-00	.PLATE, LOCK	5				

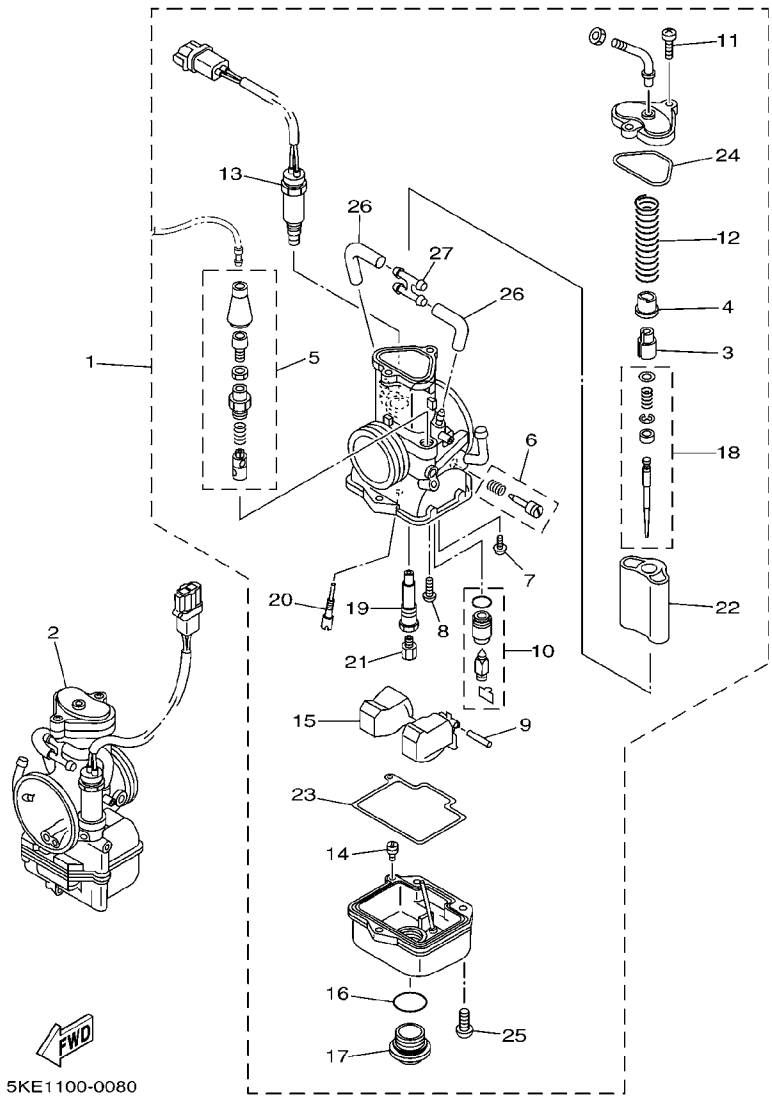
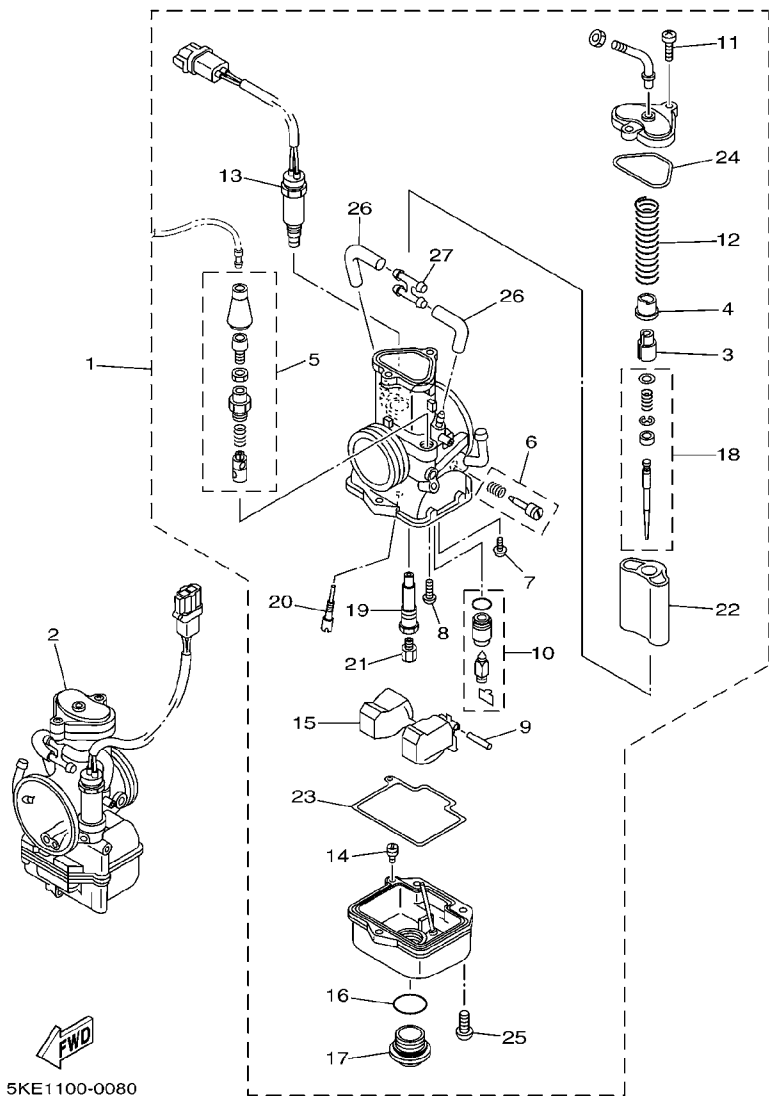

FIG. 8 CARBURETOR

REF NO.	PART NO.	DESCRIPTION	5KE4				REMARKS
1	5KE-14101-30	CARBURETOR ASSY 1	1				
2	5KE-14102-30	CARBURETOR ASSY 2	1				
3	5KE-14261-00	.HOLDER	1				
4	4PE-14194-00	.RING	1				
5	4TW-1410A-00	.STARTER SET	1				
6	3JD-14104-00	.AIR SCREW SET	1				
7	1FN-14565-00	.SCREW	1				
8	98507-04008	.SCREW, PAN HEAD	1				
9	353-14186-00	.PIN, FLOAT	1				
10	4TW-14107-17	.NEEDLE VALVE SET	1				
11	98507-04014	.SCREW, PAN HEAD	2				
12	4TW-14131-00	.SPRING, THROTTLE VALVE	1				
13	5KE-1410H-00	.FUEL CUT SOLENOID VALVE	1				
14	830-14231-13	JET, MAIN (# 65)	1				STD
	830-14231-11	JET, MAIN (# 55)	1				AP
	830-14231-12	JET, MAIN (# 60)	1				AP
15	5ET-14185-00	.FLOAT	1				
16	2K6-14147-00	.O-RING	1				
17	5ET-14115-00	.PLUG, SCREW	1				
18	5KE-1490J-30	.NEEDLE SET	1				
19	5KE-14141-S5	.NOZZLE, MAIN (S-5)	1				STD
	5KE-14141-S0	.NOZZLE, MAIN (S-0)	1				AP
	5KE-14141-S1	.NOZZLE, MAIN (S-1)	1				AP
	5KE-14141-S2	.NOZZLE, MAIN (S-2)	1				AP
	5KE-14141-S3	.NOZZLE, MAIN (S-3)	1				AP
	5KE-14141-S4	.NOZZLE, MAIN (S-4)	1				AP
	5KE-14141-R9	.NOZZLE, MAIN (R-9)	1				AP



5KE1100-0080

FIG. 8 CARBURETOR

REF NO.	PART NO.	DESCRIPTION	5KE4				REMARKS
20	4KM-14142-35	JET, PILOT (# 35)	1				STD
	4KM-14142-25	JET, PILOT (# 25)	1				AP
	4KM-14142-30	JET, PILOT (# 30)	1				AP
21	137-1414K-00	JET, MAIN (#500)	1				STD
	137-14143-70	JET, MAIN (#350)	1				AP
	137-14143-72	JET, MAIN (#360)	1				AP
	137-14143-74	JET, MAIN (#370)	1				AP
	137-14143-76	JET, MAIN (#380)	1				AP
	137-14143-78	JET, MAIN (#390)	1				AP
	137-14143-80	JET, MAIN (#400)	1				AP
	137-14143-82	JET, MAIN (#410)	1				AP
	137-14143-84	JET, MAIN (#420)	1				AP
	137-14143-86	JET, MAIN (#430)	1				AP
	137-14143-88	JET, MAIN (#440)	1				AP
	137-14143-90	JET, MAIN (#450)	1				AP
	137-14143-92	JET, MAIN (#460)	1				AP
	137-14143-94	JET, MAIN (#470)	1				AP
	137-14143-96	JET, MAIN (#480)	1				AP
	137-14143-98	JET, MAIN (#490)	1				AP
22	5KE-14112-60	VALVE, THROTTLE 1	1				
23	4TW-1416A-00	O-RING	1				
24	5ET-14147-00	O-RING	1				
25	98507-05014	SCREW, PAN HEAD	3				
26	4TW-14197-00	PIPE	2				
27	8J0-14251-00	NIPPLE	1				

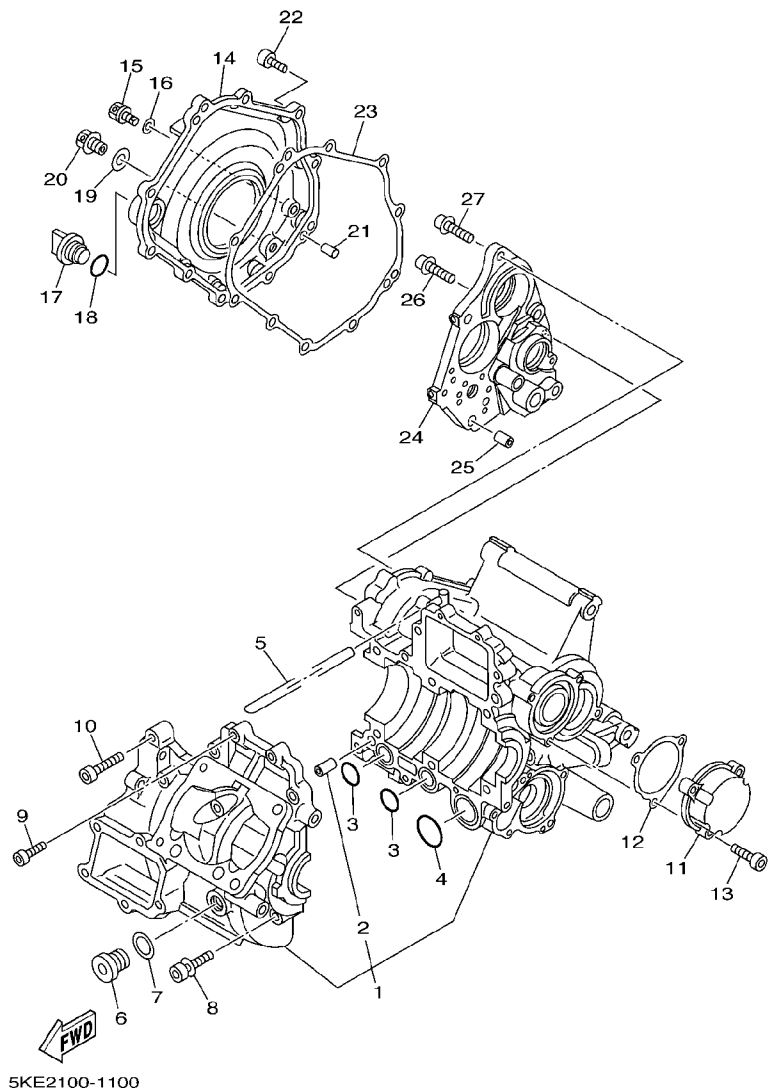

FIG. 10 CRANKCASE

REF NO.	PART NO.	DESCRIPTION	5KE4				REMARKS
1	5KE-15100-02	CRANKCASE ASSY	1				
2	99530-10014	.PIN, DOWEL	2				
3	93210-19758	O-RING	2				
4	93210-28543	O-RING	1				
5	90445-093H5	HOSE (L330)	1				
6	90340-18101	PLUG, STRAIGHT SCREW	1				
7	90201-183H2	WASHER, PLATE	1				
8	90109-084F1	BOLT	6				
9	91317-06030	BOLT	6				
10	91314-06035	BOLT	3				
11	5KE-15411-00	COVER, CRANKCASE 1	1				
12	5KE-15451-00	GASKET, CRANKCASE COVER 1	1				
13	91317-06025	BOLT	3				
14	5KE-15421-00	COVER, CRANKCASE 2	1				
15	90338-06041	PLUG	1				
16	90430-06166	GASKET	1				
17	4A0-15363-00	PLUG, OIL	1				
18	93210-21190	O-RING	1				
19	90430-12202	GASKET	1				
20	90340-12144	PLUG, STRAIGHT SCREW	1				
21	93606-12019	PIN, DOWEL	2				
22	91317-06020	BOLT	10				
23	5KE-15461-00	GASKET, CRANKCASE COVER 2	1				
24	5KE-15131-00	CRANKCASE 3	1				
25	99530-10014	PIN, DOWEL	2				
26	90109-06028	BOLT	2				
27	90109-06029	BOLT	4				

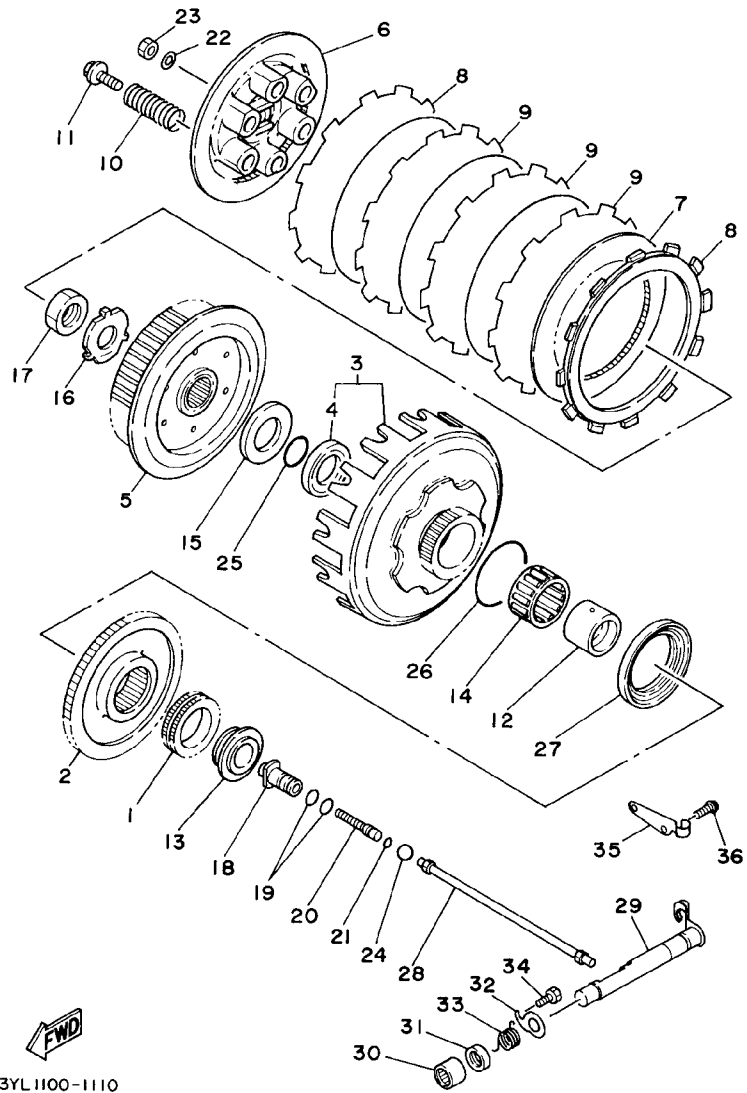
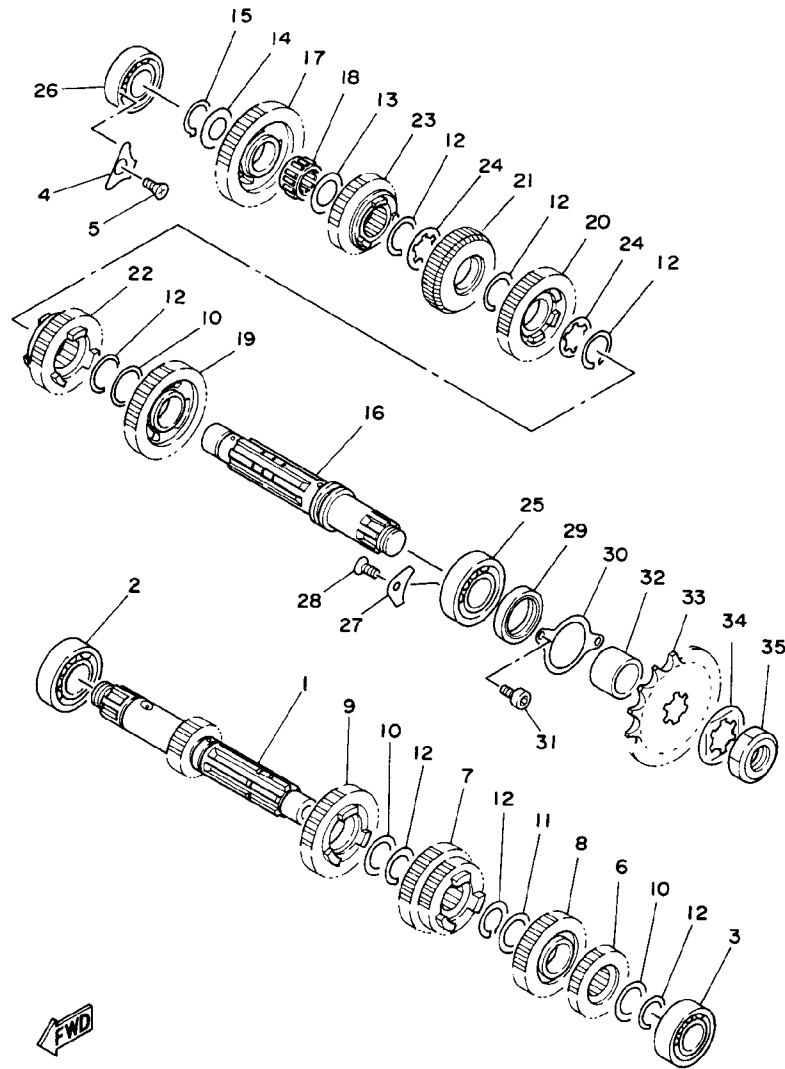

FIG. 11 CLUTCH

REF NO.	PART NO.	DESCRIPTION	5KE4				REMARKS
1	4DP-13324-00	GEAR, PUMP DRIVE	1				
2	5KE-16151-00	GEAR, PRIMARY DRIVEN	1				
3	5KE-16310-00	CLUTCH HOUSING ASSY	1				
4	93102-30243	.OIL SEAL	1				
5	3R4-16371-01	BOSS, CLUTCH	1				
6	26J-16351-00	PLATE, PRESSURE 1	1				
7	168-16324-00	PLATE, CLUTCH 1 (T=2.3)	5				
8	3YL-16321-01	PLATE, FRICTION	2				
9	3AK-16321-00	PLATE, FRICTION	4				
10	90501-230A5	SPRING, COMPRESSION	6				
11	90159-06016	SCREW, WITH WASHER	6				
12	5F7-16181-00	SPACER 1	1				
13	3YL-16154-00	PLATE, THRUST 1	1				
14	93310-332J5	BEARING	1				
15	5F7-16153-00	WASHER, THRUST	1				
16	90215-20212	WASHER, LOCK	1				
17	90170-20255	NUT	1				
18	59W-16356-00	ROD, PUSH 1	1				
19	93210-09165	O-RING	2				
20	5F7-16343-00	SCREW, ADJUSTING	1				
21	93210-04279	O-RING	1				
22	92907-06200	WASHER	1				
23	95307-06600	NUT	1				
24	93515-32029	BALL	1				
25	93210-22164	O-RING	1				
26	93210-42482	O-RING	1				
27	93101-56095	OIL SEAL	1				



4DP2100-3121

FIG. 12 TRANSMISSION

REF NO.	PART NO.	DESCRIPTION	5KE4			REMARKS
1	5KE-17411-30	AXLE, MAIN (16T)	1			
2	93306-20526	BEARING (B6205)	1			
3	93306-00442	BEARING	1			
4	5KE-15381-00	PLATE, BEARING COVER	1			
5	90151-06001	SCREW, COUNTERSUNK	1			
6	4DP-17121-12	GEAR, 2ND PINION (21T)	1			
7	5KE-17131-30	GEAR, 3RD/4TH PINION (21T/22T)	1			
8	3YL-17151-30	GEAR, 5TH PINION (21T)	1			
9	5KE-17161-30	GEAR, 6TH PINION (27T)	1			
10	90201-253K0	WASHER, PLATE (T=1.0)	3			UN
	90201-253E6	WASHER, PLATE (T=0.9)	3			UN
11	90201-253E4	WASHER, PLATE (T=1.5)	1			
12	93440-25084	CIRCLIP	7			
13	90201-20276	WASHER, PLATE (T=1.0)	1			
14	90201-20276	WASHER, PLATE (T=1.0)	1			UN
	90201-206E5	WASHER, PLATE (T=0.9)	1			UN
15	99009-20400	CIRCLIP	1			
16	5KE-17421-00	AXLE, DRIVE	1			
17	5KE-17211-30	GEAR, 1ST WHEEL (31T)	1			
18	93310-22057	BEARING (K20-24X10 S)	1			
19	4DP-17221-12	GEAR, 2ND WHEEL (31T)	1			
20	5KE-17231-10	GEAR, 3RD WHEEL (26T)	1			
21	5KE-17241-10	GEAR, 4TH WHEEL (24T)	1			
22	3YL-17251-30	GEAR, 5TH WHEEL (21T)	1			
23	5KE-17261-30	GEAR, 6TH WHEEL (25T)	1			
24	5F7-17136-00	WASHER (T=0.7)	2			UN
	90209-22082	WASHER (T=0.5)	2			UN

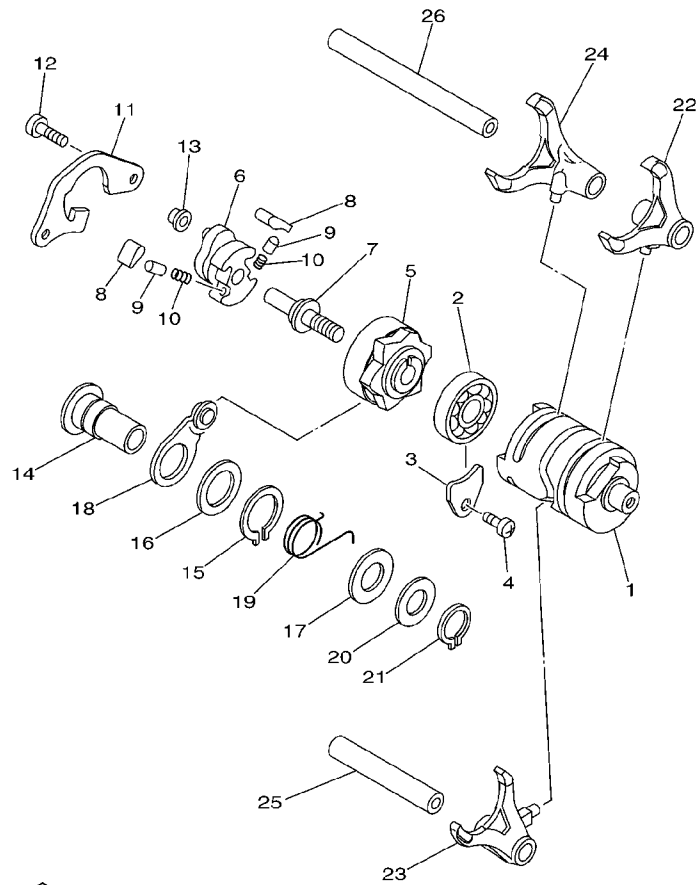

5KE1100-0130

FIG. 13 SHIFT CAM FORK

REF NO.	PART NO.	DESCRIPTION	5KE4				REMARKS
1	5KE-18541-00	CAM, SHIFT	1				
2	93306-90302	BEARING	1				
3	3XV-18562-00	PLATE, STOPPER 2	1				
4	90157-05004	SCREW, PAN HEAD	1				
5	3YL-18185-00	SEGMENT	1				
6	3XV-18122-00	LEVER, SHIFT 2	1				
7	3XV-18173-00	PIN, SHIFT	1				
8	3YL-18182-00	PAWL, SHIFTER	2				
9	3YL-18184-00	PIN, PAWL	2				
10	90501-052G5	SPRING, COMPRESSION	2				
11	5KE-18172-00	GUIDE, SHIFT	1				
12	91318-06014	BOLT	2				
13	3XJ-18178-00	ROLLER, SHIFT LEVER	1				
14	90387-127V3	COLLAR	1				
15	99009-17400	CIRCLIP	1				
16	90201-177G4	WASHER, PLATE	1				
17	90201-154E8	WASHER, PLATE (T=1.0)	1				
18	3XV-18140-00	STOPPER LEVER ASSY	1				
19	90508-231A5	SPRING, TORSION	1				
20	90201-127E1	WASHER, PLATE	1				
21	99009-12400	CIRCLIP	1				
22	5KE-18511-00	FORK, SHIFT 1	1				
23	5KE-18512-00	FORK, SHIFT 2	1				
24	5KE-18513-00	FORK, SHIFT 3	1				
25	3XV-18531-00	BAR, SHIFT FORK GUIDE 1	1				
26	5KE-18535-00	BAR, SHIFT FORK GUIDE 2	1				

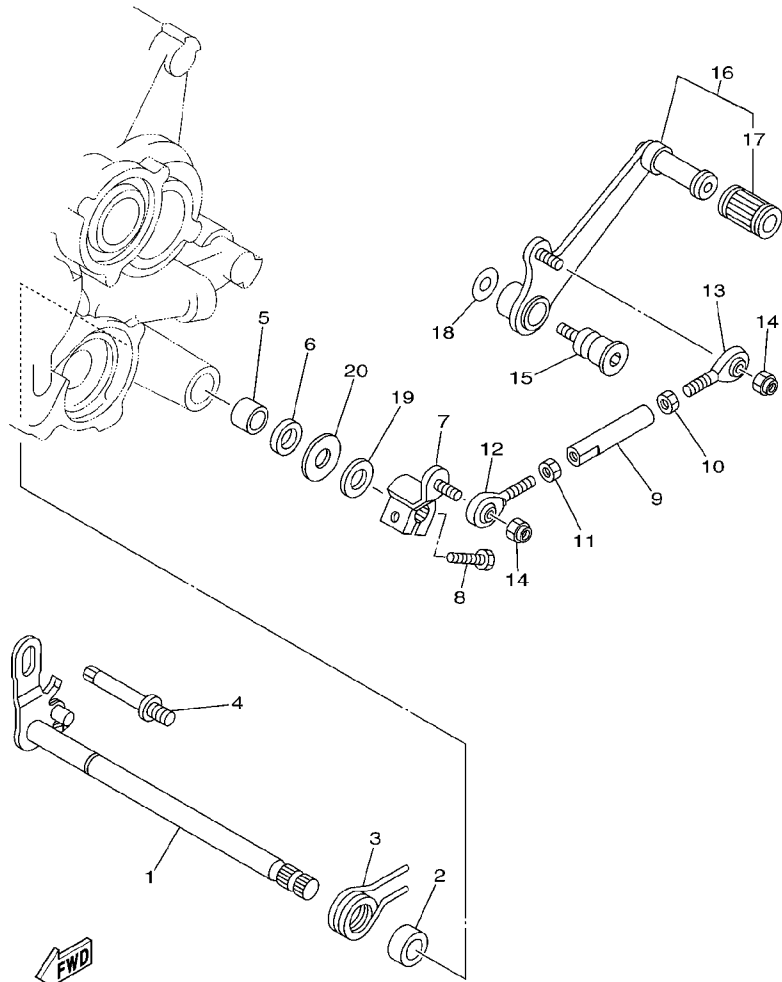

5KE1100-0140

FIG. 14 SHIFT SHAFT

REF NO.	PART NO.	DESCRIPTION	5KE4				REMARKS
1	5KE-18101-00	SHIFT SHAFT ASSY	1				
2	90560-12361	SPACER	1				
3	90508-29742	SPRING, TORSION	1				
4	3MA-18127-00	STOPPER, SCREW	1				
5	90383-12013	BUSH, FORMED	1				
6	93109-12012	OIL SEAL	1				
7	4DP-18112-00	ARM, SHIFT	1				
8	97017-06020	BOLT	1				
9	5KE-18115-00	ROD, SHIFT	1				
10	90170-06228	NUT(COUNTER CLOCKWISE)	1				
11	95304-06700	NUT	1				
12	3TC-18116-00	JOINT, ROD 1	1				
13	3TC-18117-00	JOINT, ROD 2	1				
14	95607-06100	NUT, U	2				
15	90109-087F6	BOLT	1				
16	4DP-18110-00	SHIFT PEDAL ASSY	1				
17	3FV-18113-00	COVER, SHIFT PEDAL	1				
18	90201-087F0	WASHER, PLATE	1				
19	90560-12075	SPACER	1				
20	90201-12588	WASHER, PLATE	1				

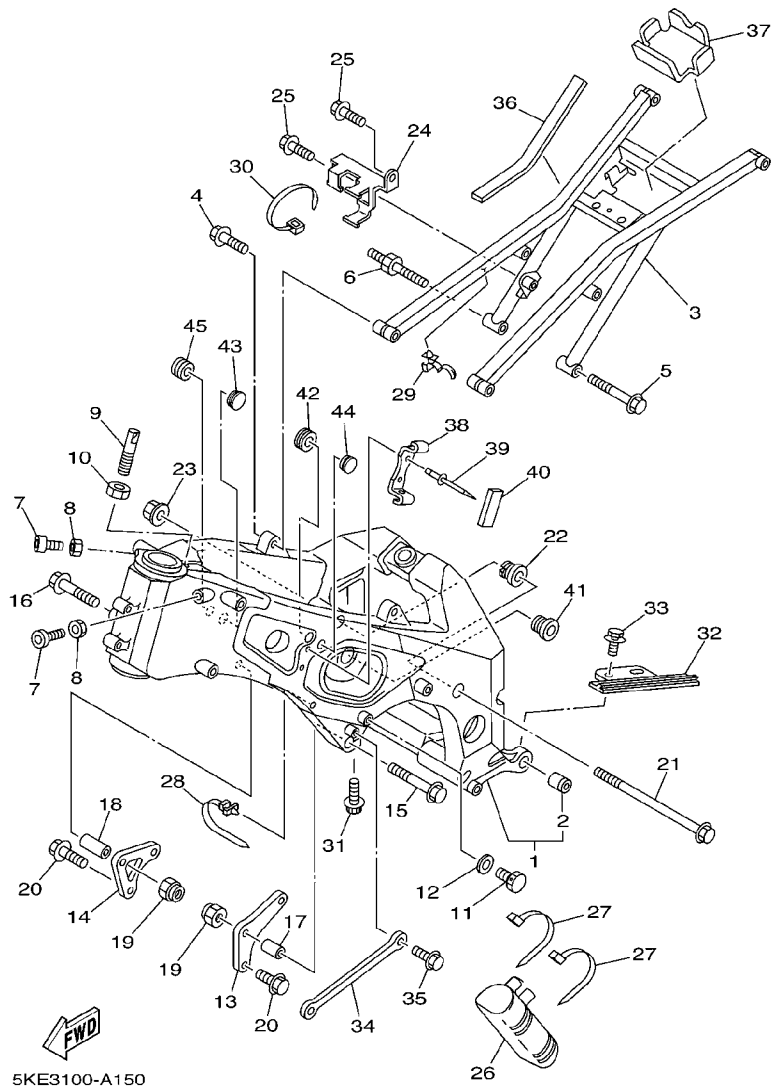
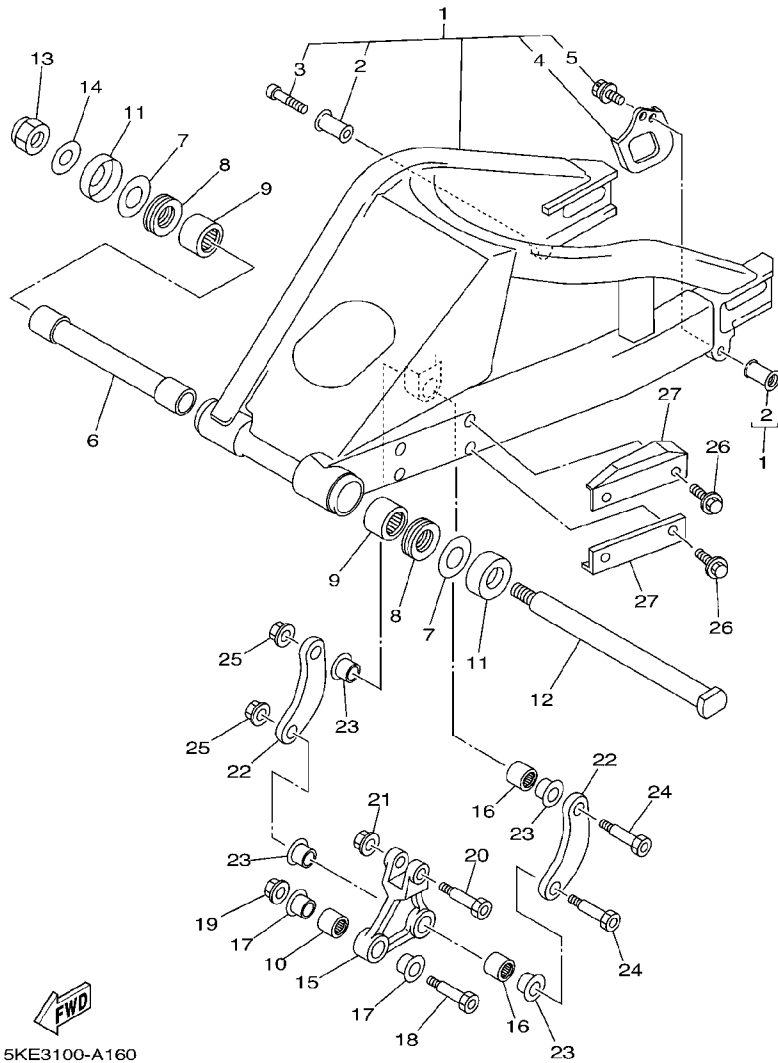

FIG. 15 FRAME

REF NO.	PART NO.	DESCRIPTION	5KE4				REMARKS
1	5KE-21110-01	FRAME COMP.	1				
2	36Y-27414-00	.DAMPER, FOOTREST	1				
3	4TW-21190-02	REAR FRAME COMP.	1				
4	95827-06025	BOLT, FLANGE	2				
5	95827-06045	BOLT, FLANGE	1				
6	5KE-2171V-00	BOLT	1				
7	91317-06020	BOLT	2				
8	95307-06600	NUT	2				
9	5KE-2134T-00	BOLT, TANK FITTING	1				
10	95307-08700	NUT	1				
11	90388-06041	PLUG	2				
12	90430-06166	GASKET	2				
13	5KE-21411-00	BRACKET, ENGINE 1	1				
14	5KE-21419-00	BRACKET, ENGINE 2	1				
15	95827-10045	BOLT, FLANGE	1				
16	95827-10060	BOLT, FLANGE	1				
17	4JT-21118-00	SLEEVE, 2	1				
18	5KE-2119T-10	SLEEVE 2	1				
19	95607-10200	NUT, SELF-LOCKING	2				
20	95027-08020	BOLT, FLANGE	4				
21	90105-10300	BOLT, FLANGE	2				
22	4JT-21495-10	BOLT, ENGINE ADJUSTING	2				
23	90179-10696	NUT	2				
24	5KE-2134V-00	BRACKET	1				
25	95027-06012	BOLT, FLANGE	2				
26	3YL-21751-00	TANK, OIL	1				
27	90465-13275	CLAMP	2				



5KE3100-A160

FIG. 16 REAR ARM

REF NO.	PART NO.	DESCRIPTION	5KE4				REMARKS
1	4TW-22110-02	REAR ARM COMP.	1				
2	4JT-2216F-10	.HOOK	2				
3	91317-06040	.BOLT	2				
4	4TW-22187-10	.GUIDE, CHAIN	1				
5	90119-06228	.BOLT, WITH WASHER	2				
6	3XV-22184-00	BUSH	1				
7	1X2-22127-00-20	SHIM (0.2T)	2				
8	93342-22516	BEARING	2				
9	93315-42523	BEARING	2				
10	93320-21507	BEARING	1				
11	3FV-22128-00	COVER, THRUST 1	2				
12	3MA-22141-01	SHAFT, PIVOT	1				
13	90185-18104	NUT, SELF-LOCKING	1				
14	92907-18200	WASHER	1				
15	5KE-2217A-00	ARM, RELAY	1				
16	93320-21507	BEARING	2				
17	90387-124Y8	COLLAR	2				
18	90101-10709	BOLT	1				
19	95607-10200	NUT, SELF-LOCKING	1				
20	90101-10709	BOLT	1				
21	95607-10200	NUT, SELF-LOCKING	1				
22	5KE-2217F-00	ROD, CONNECTING 1	2				
23	90387-124Y8	COLLAR	4				
24	90101-10709	BOLT	2				
25	95607-10200	NUT, SELF-LOCKING	2				
26	90119-06227	BOLT, WITH WASHER	4				
27	4TW-22147-00	PROTECTOR, CHAIN	2				

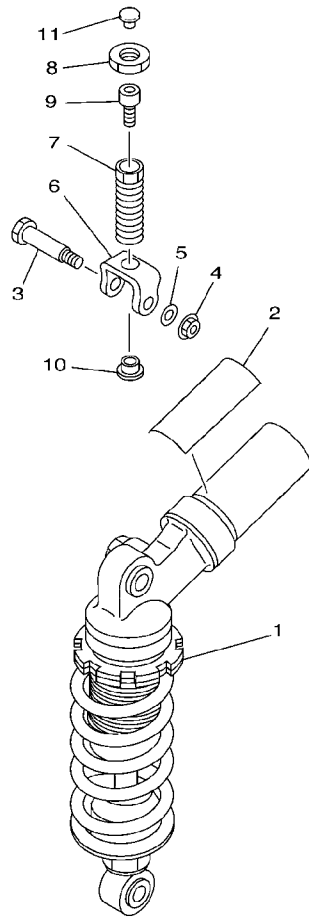

FIG. 17 REAR SUSPENSION

REF NO.	PART NO.	DESCRIPTION	5KE4				REMARKS
1	5KE-22210-10	SHOCK ABSORBER ASSY, REAR	1				
2	4AA-22259-50	LABEL, WARNING	1				
3	90101-10709	BOLT	1				
4	95607-10200	NUT, SELF-LOCKING	1				
5	90201-127J6	WASHER, PLATE	1				
6	4JT-22219-00	BRACKET, UPPER	1				
7	4JT-22239-00	ADJUSTER	1				
8	1RK-22251-00	NUT 1	1				
9	91317-10016	BOLT	1				
10	3AK-22252-00	NUT	1				
11	90480-14153	GROMMET	1				



5KE2110-1170

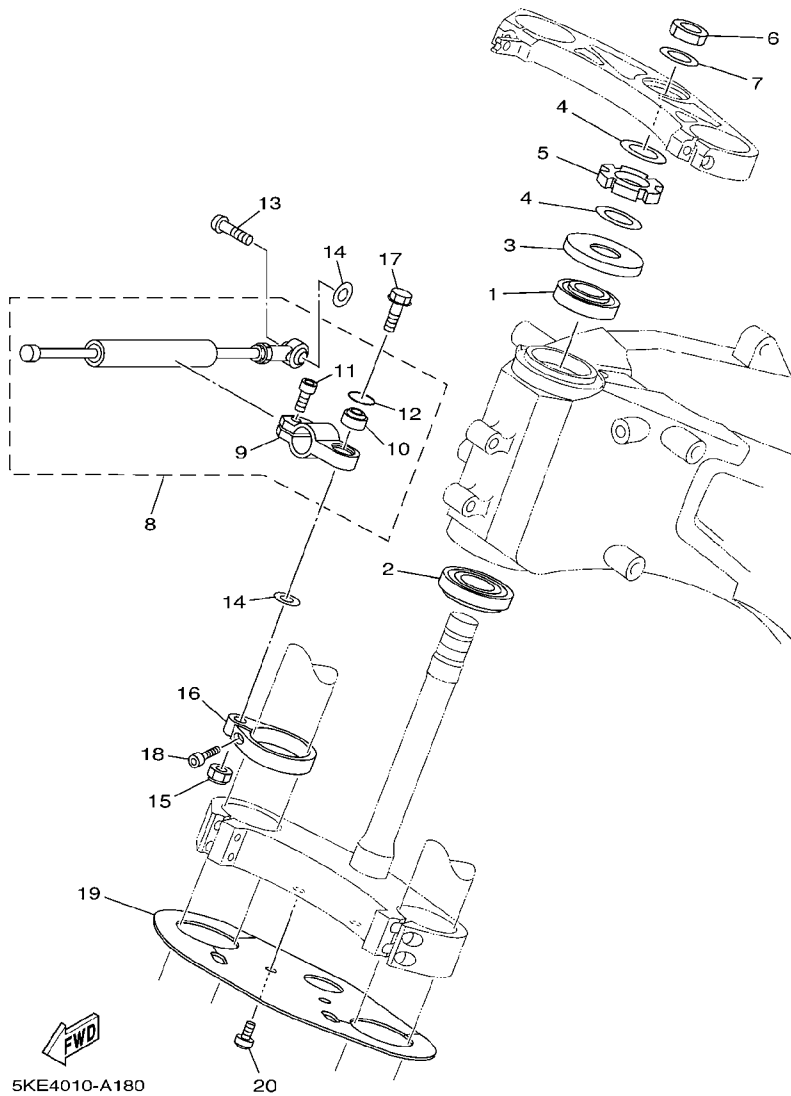

FIG. 18 STEERING

REF NO.	PART NO.	DESCRIPTION	5KE4				REMARKS
1	93332-00001	BEARING	1				
2	93332-00081	BEARING	1				
3	1J7-23415-00	COVER, BALL RACE 1	1				
4	90201-25526	WASHER, PLATE (T=2.0)	2				
5	90179-25033	NUT	1				
6	1RK-22251-00	NUT 1	1				
7	90201-225A4	WASHER, PLATE (T=1.0)	1				
8	5KE-23490-10	HANDLEBAR SHIMMY DAMPER ASSY	1				
9	5KE-2331W-00	.BRACKET, UPPER	1				
10	93399-999T7	.BEARING	1				
11	91314-06016	.BOLT	1				
12	93450-21053	.CIRCLIP	1				
13	90109-084F7	BOLT	1				
14	90201-08M12	WASHER, PLATE	2				
15	95607-08100	NUT, U	1				
16	5KE-23495-10	STAY, DAMPER	1				
17	95827-08035	BOLT, FLANGE	1				
18	91317-06020	BOLT	1				
19	5KE-21552-20	FENDER, INNER	1				
20	90150-06021	SCREW, ROUND HEAD	2				

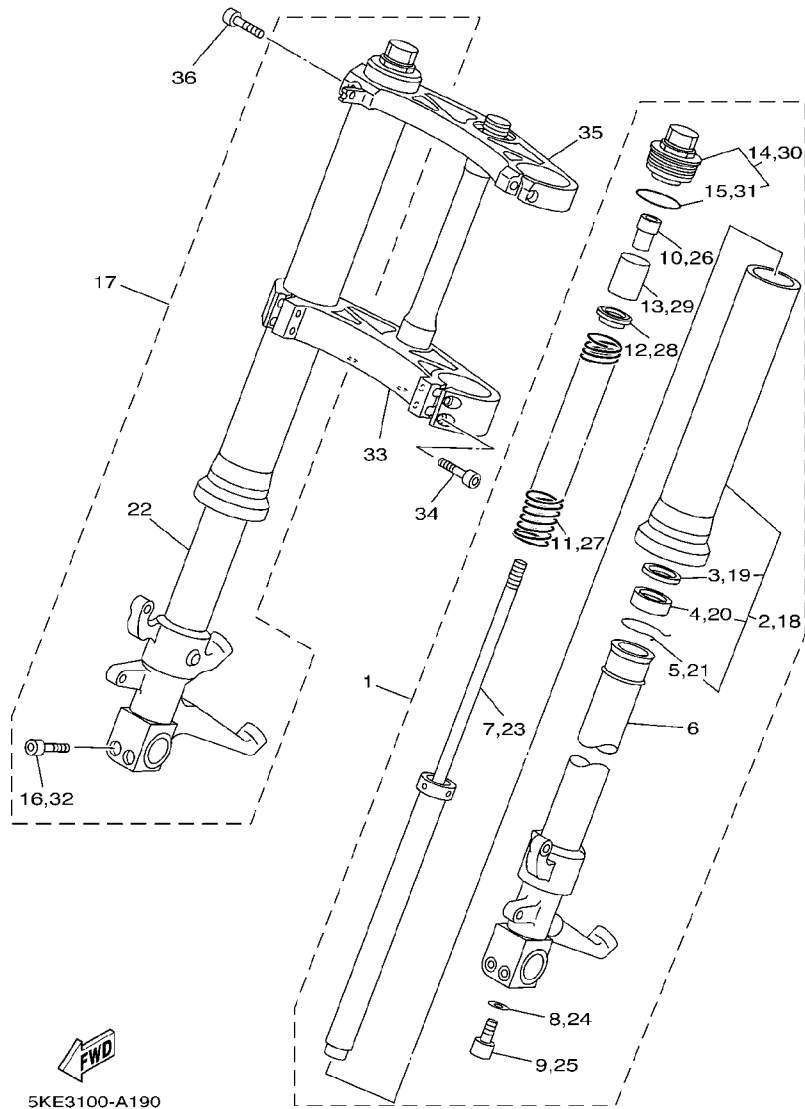

FIG. 19 FRONT FORK

REF NO.	PART NO.	DESCRIPTION	5KE4				REMARKS
1	5KE-23102-20	FRONT FORK ASSY (L.H)	1				
2	5KE-23136-00	.TUBE, OUTER (RIGHT)	1				
3	36Y-23146-10	..WASHER, OIL SEAL	1				
4	3JD-23145-L0	..OIL SEAL	1				
5	26H-23156-00	..CLIP, OIL SEAL	1				
6	5KE-23110-20	..INNER TUBE COMP.1	1				
7	5KE-23170-10	..CYLINDER COMP., FRONT FORK	1				
8	2KS-23158-L0	..GASKET	1				
9	3LC-23181-00	..BOLT, HEXAGON SOCKET HEAD	1				
10	4TW-23357-10	..NUT	1				
11	3YL-23141-00	..SPRING, FRONT FORK	1				
12	4TW-23142-10	..SEAT, SPRING UPPER	1				
13	4TW-23118-10	..SPACER	1				
14	4TW-23111-10	..BOLT, CAP	1				
15	3SP-23147-M0	..O-RING	1				
16	5KE-23128-00	..BOLT, AXLE HOLDER	2				
17	5KE-23103-20	FRONT FORK ASSY (R.H)	1				
18	5KE-23136-00	.TUBE, OUTER (RIGHT)	1				
19	36Y-23146-10	..WASHER, OIL SEAL	1				
20	3JD-23145-L0	..OIL SEAL	1				
21	26H-23156-00	..CLIP, OIL SEAL	1				
22	5KE-23120-20	..INNER TUBE COMP.2	1				
23	5KE-23170-10	..CYLINDER COMP., FRONT FORK	1				
24	2KS-23158-L0	..GASKET	1				
25	3LC-23181-00	..BOLT, HEXAGON SOCKET HEAD	1				
26	4TW-23357-10	..NUT	1				
27	3YL-23141-00	..SPRING, FRONT FORK	1				

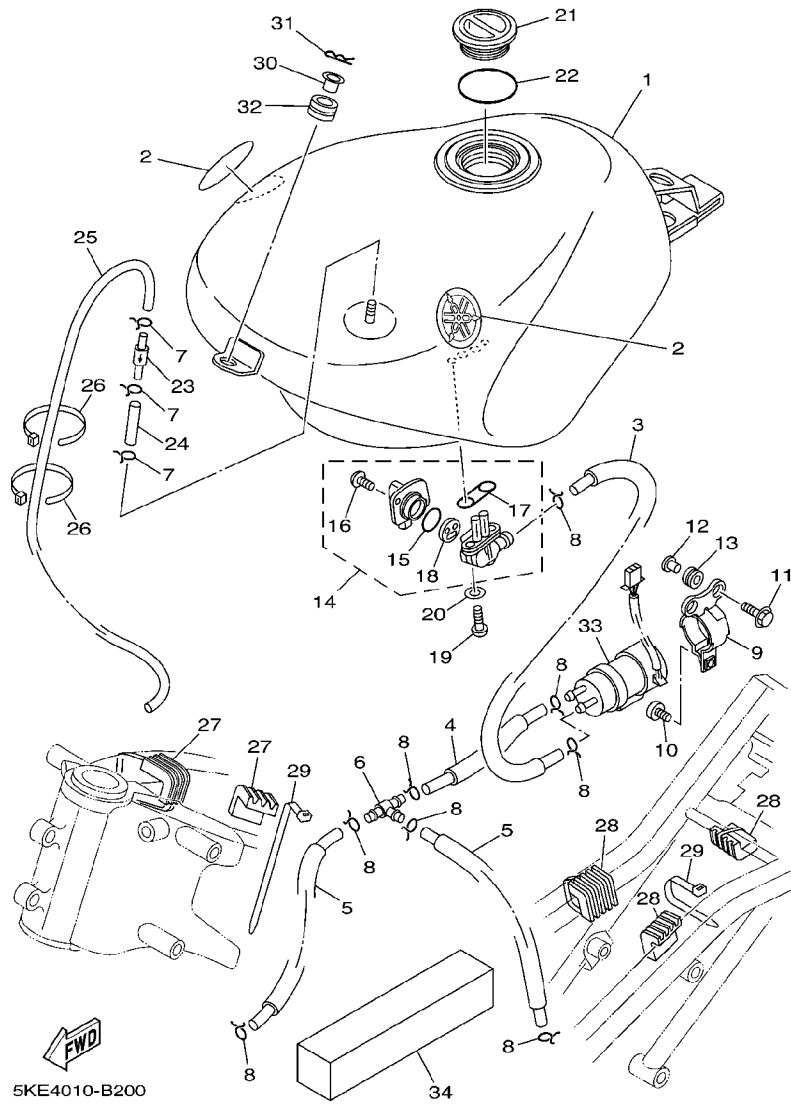
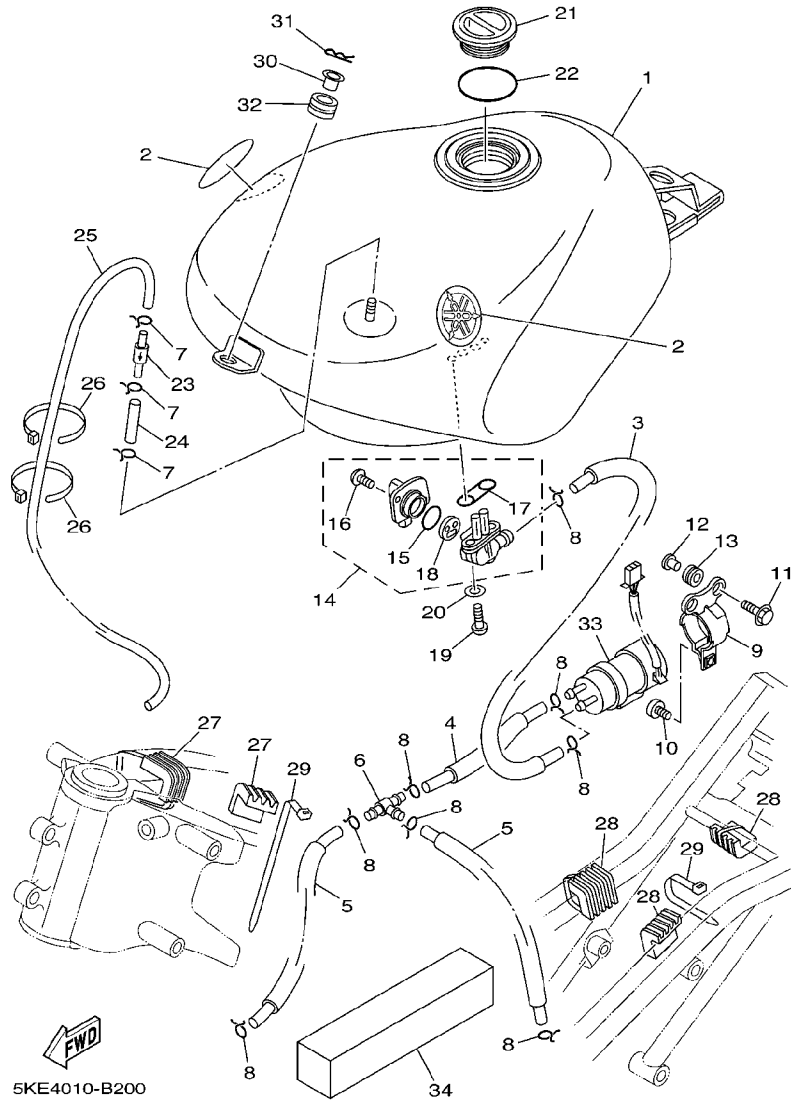

FIG. 20 FUEL TANK

REF NO.	PART NO.	DESCRIPTION	5KE4				REMARKS
1	5KE-24110-00-36	FUEL TANK COMP.	1				WW
2	5KE-2411B-00	EMBLEM	2				
3	5KE-24311-00	PIPE, FUEL 1	1				
4	5KE-24312-10	PIPE 2	1				
5	5KE-24313-00	PIPE 3	2				
6	69J-24378-00	PIPE, JOINT 4	1				
7	90467-09006	CLIP	3				
8	90467-10008	CLIP	8				
9	3CV-24491-10	BRACKET, FUEL PUMP	1				
10	98907-05008	SCREW, BIND	1				
11	90119-06096	BOLT, WITH WASHER	2				
12	90387-06737	COLLAR	2				
13	90480-13163	GROMMET	2				
14	4JT-24500-00	FUEL COCK ASSY 1	1				
15	3AJ-24534-00	.SEAL, COCK	1				
16	97801-03008	.SCREW, PAN HEAD	2				
17	4X8-24512-00	.O-RING	1				
18	3AJ-24523-00	.VALVE PACKING	1				
19	90149-06011	SCREW	2				
20	90202-05193	WASHER, PLATE	2				
21	4JT-24611-00	BODY, CAP	1				
22	4JT-24612-00	GASKET, CAP	1				
23	3XJ-24380-00	PIPE JOINT ASSY	1				
24	91A20-05004	TUBE, FLEXIBLE VINYL	1				
25	91A20-05065	TUBE, FLEXIBLE VINYL	1				
26	90465-13152	CLAMP	2				
27	4DP-24181-00	DAMPER, LOCATING 1	2				

FIG. 20 FUEL TANK



REF NO.	PART NO.	DESCRIPTION	5KE4				REMARKS
28	3LC-24182-00	DAMPER, LOCATING 2	3				
29	90465-13275	CLAMP	5				
30	90387-081F5	COLLAR	1				
31	4JT-2411M-00	CLIP	1				
32	90480-18525	GROMMET	1				
33	4NK-13907-00	FUEL PUMP COMP.	1				
34	4JT-2411R-00	PLATE 1	10				AP

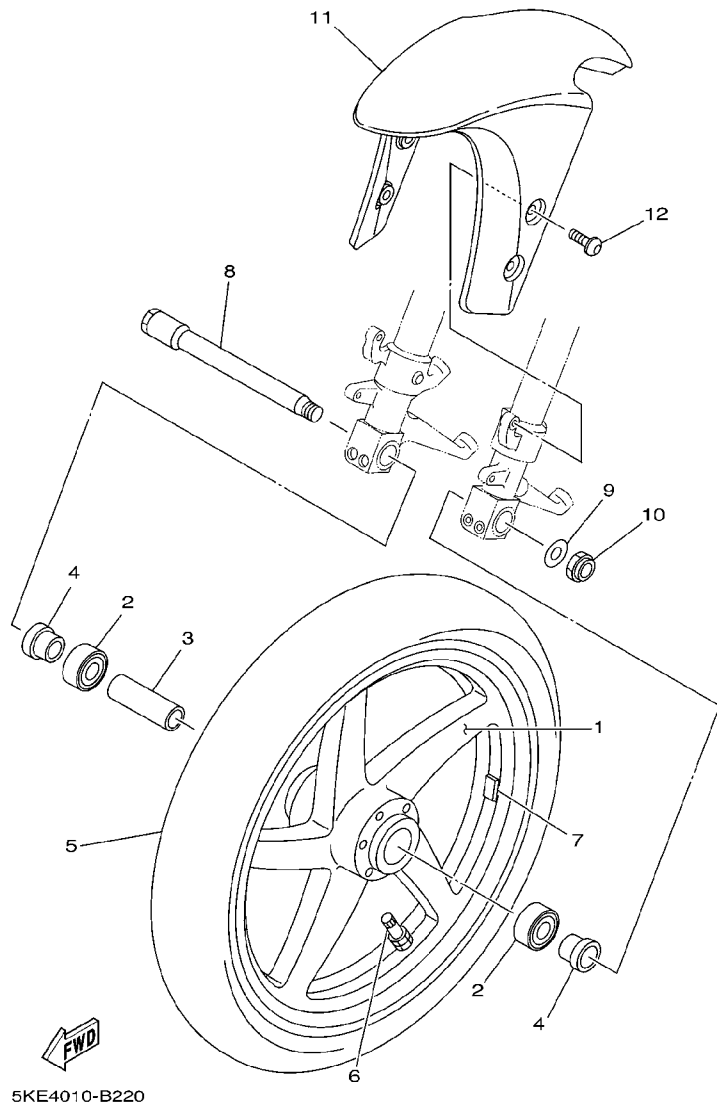

FIG. 22 FRONT WHEEL

REF NO.	PART NO.	DESCRIPTION	5KE4				REMARKS
1	4TW-25168-00	CAST WHEEL, FRONT	1				
2	93306-00521	BEARING	2				
3	4TW-25117-00	SPACER, BEARING	1				
4	4TW-25183-00	COLLAR, WHEEL	2				
5	94112-1713L	TIRE (120/60 ZR17 KR106)	1				DUNLOP
6	93900-00031	VALVE, RIM	1				
7	4TW-25398-00	BALANCER, WHEEL	1				UN
8	4DP-25181-10	AXLE, WHEEL	1				
9	90201-183E1	WASHER, PLATE	1				
10	90185-18104	NUT, SELF-LOCKING	1				
11	5KE-21510-00	FRONT FENDER COMP.	1				
12	90111-06023	BOLT	4				

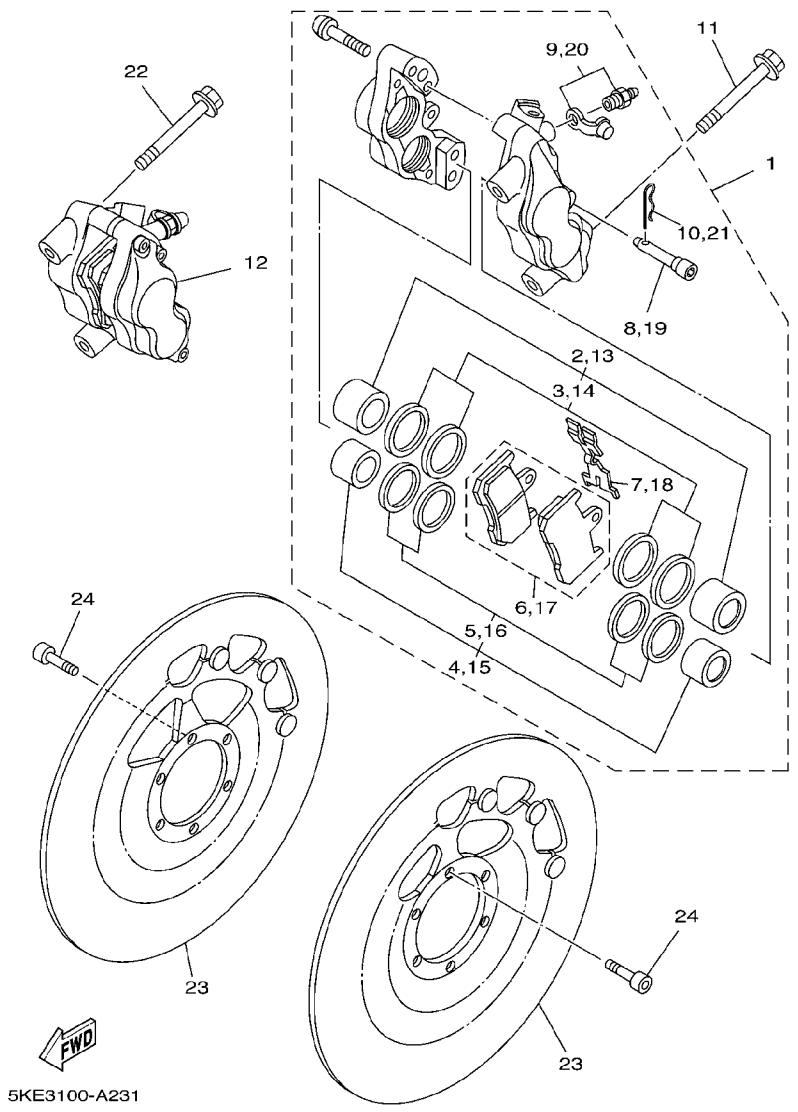

FIG. 23 FRONT BRAKE CALIPER

REF NO.	PART NO.	DESCRIPTION	5KE4				REMARKS
1	5KE-2580T-00	CALIPER ASSY (LEFT)	1				
2	4TW-W0057-00	.PISTON ASSY, CALIPER	1				
3	4TW-W0047-00	..CALIPER SEAL KIT	1				
4	4TW-W0057-10	.PISTON ASSY, CALIPER	1				
5	4TW-W0047-10	..CALIPER SEALKIT	1				
6	5KE-W0045-00	.BRAKE PAD KIT	1				
7	5KE-25919-00	.SUPPORT, PAD	1				
8	5KE-25924-00	.PIN, PAD	1				
9	1UY-W0048-50	.BLEED SCREW KIT	1				
10	90468-10050	.CLIP	1				
11	5KE-25818-00	BOLT, CALIPER	2				
12	5KE-2580U-00	CALIPER ASSY (RIGHT)	1				
13	4TW-W0057-00	.PISTON ASSY, CALIPER	1				
14	4TW-W0047-00	..CALIPER SEALKIT	1				
15	4TW-W0057-10	.PISTON ASSY, CALIPER	1				
16	4TW-W0047-10	..CALIPER SEALKIT	1				
17	5KE-W0045-00	.BRAKE PAD KIT	1				
18	5KE-25919-00	.SUPPORT, PAD	1				
19	5KE-25924-00	.PIN, PAD	1				
20	1UY-W0048-50	.BLEED SCREW KIT	1				
21	90468-10050	.CLIP	1				
22	5KE-25818-00	BOLT, CALIPER	2				
23	4JT-2581T-00	DISC BRAKE ASSY	2				
24	90110-08193	BOLT, HEXAGON SOCKET HEAD	12				

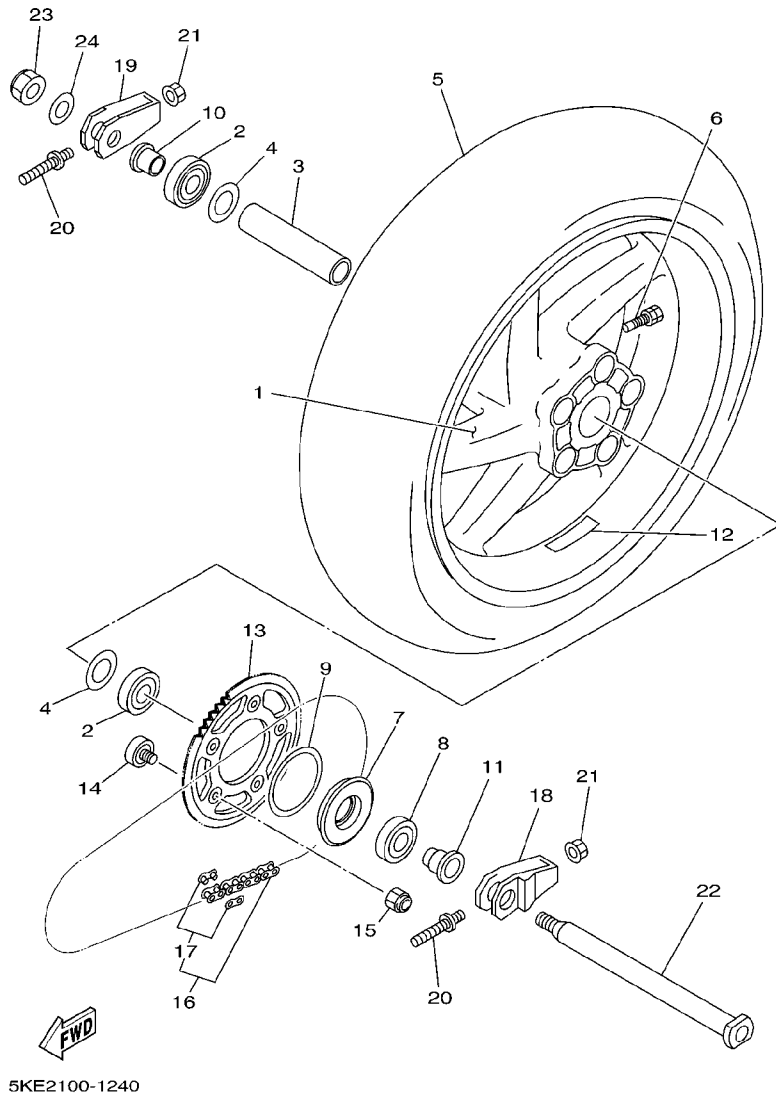

FIG. 24 REAR WHEEL

REF NO.	PART NO.	DESCRIPTION	5KE4				REMARKS
1	5KE-25338-00	CAST WHEEL, REAR	1				
2	93306-00521	BEARING	2				
3	4TW-25317-00	SPACER, BEARING	1				
4	4DP-2518A-00	PLATE, FITTING	2				
5	94116-1713M	TIRE (165/55 ZR17 KR108)	1				DUNLOP
6	93900-00031	VALVE, RIM	1				
7	5KE-25366-10	CLUTCH, HUB	1				
8	93306-90601	BEARING (B6906)	1				
9	5KE-25384-00	WASHER, WHEEL	1				
10	4TW-25383-00	COLLAR, WHEEL	1				
11	5KE-25376-00	COLLAR, WHEEL	1				
12	4TW-25398-00	BALANCER, WHEEL	1				UN
13	5KE-25436-10	SPROCKET, DRIVEN (36T)	1				STD
	5KE-25435-10	SPROCKET, DRIVEN (35T)	1				AP
	5KE-25437-10	SPROCKET, DRIVEN (37T)	1				AP
	5KE-25438-10	SPROCKET, DRIVEN (38T)	1				AP
	5KE-25439-10	SPROCKET, DRIVEN (39T)	1				AP
	5KE-25440-10	SPROCKET, DRIVEN (40T)	1				AP
14	3YL-25364-00	DAMPER	5				
15	90185-08097	NUT, SELF-LOCKING	5				
16	94561-62110	CHAIN (RKGB520TRU 110L)	1				STD
	94561-62114	CHAIN (RKGB520TRU 114L)	1				AP
17	94661-62031	JOINT, CHAIN	1				
18	4TW-25388-01	PULLER, CHAIN 1	1				
19	4TW-25389-01	PULLER, CHAIN 2	1				
20	4DP-25379-00	BOLT, CHAIN PULLAR	2				
21	90185-08097	NUT, SELF-LOCKING	2				

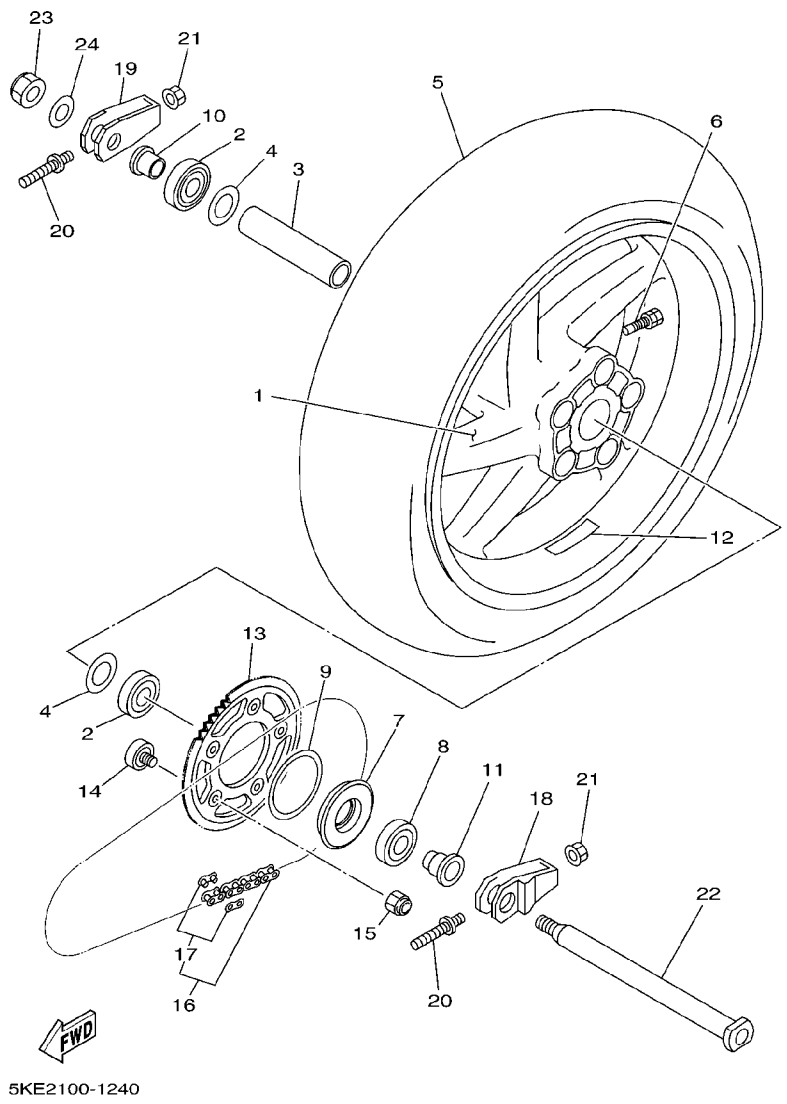
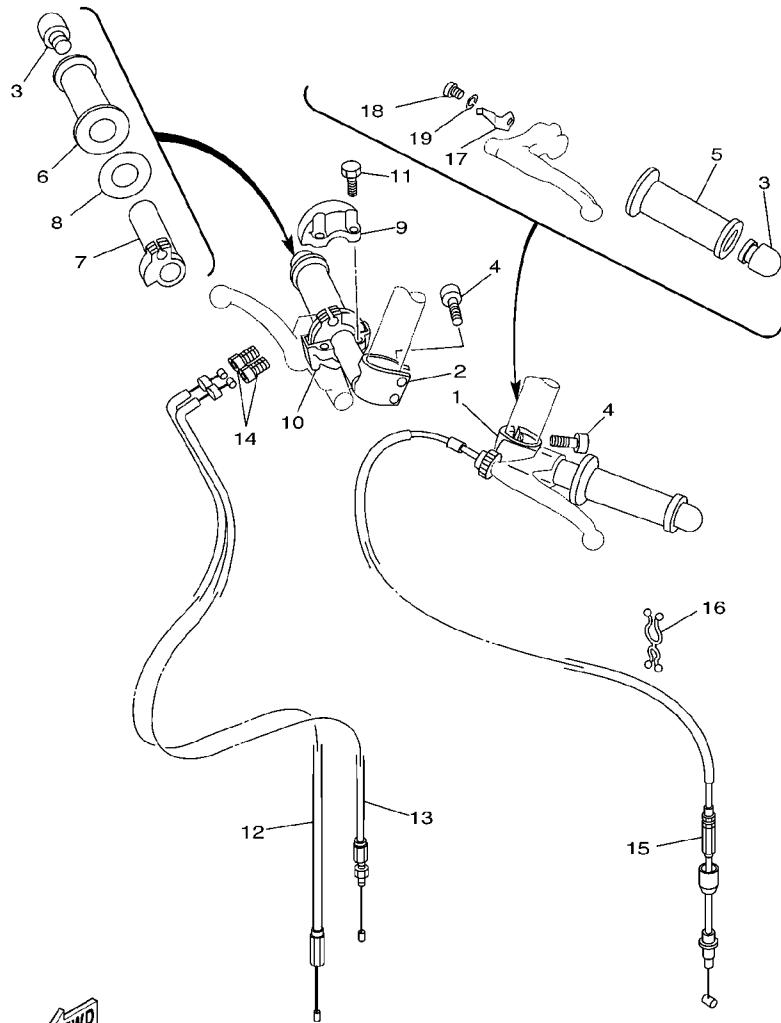

FIG. 24 REAR WHEEL

REF NO.	PART NO.	DESCRIPTION	5KE4				REMARKS
22	4TW-25381-00	AXLE, WHEEL	1				
23	90185-18104	NUT, SELF-LOCKING	1				
24	90201-183E1	WASHER, PLATE	1				
<hr/>							
<hr/>							
<hr/>							
<hr/>							
<hr/>							
<hr/>							
<hr/>							
<hr/>							
<hr/>							



4TW3100-8260

FIG. 26 STEERING HANDLE. CABLE

REF NO.	PART NO.	DESCRIPTION	5KE4				REMARKS
1	3YL-26121-00	HANDLEBAR (LEFT)	1				
2	3YL-26122-01	HANDLEBAR (RIGHT)	1				
3	4JT-26246-00	END, GRIP	2				
4	91317-06025	BOLT	4				
5	47X-26241-00	GRIP	1				
6	47X-26242-00	GRIP (RIGHT)	1				
7	3YL-26243-00	TUBE, THROTTLE GUIDE	1				
8	3Y1-26249-00	RING, LEAF	1				
9	3YL-26281-01	CAP, GRIP UPPER	1				
10	3YL-26282-00	CAP, GRIP LOWER	1				
11	91317-05020	BOLT	2				
12	5KE-26311-00	CABLE, THROTTLE 1	1				
13	5KE-26312-00	CABLE, THROTTLE 2	1				
14	90123-06007	BOLT	2				
15	5KE-26335-00	CABLE, CLUTCH	1				
16	90464-16115	CLAMP	1				
17	5F6-26368-00	SPRING, LOCK	1				
18	98507-05008	SCREW, PAN HEAD	1				
19	92907-05100	WASHER, SPRING	1				

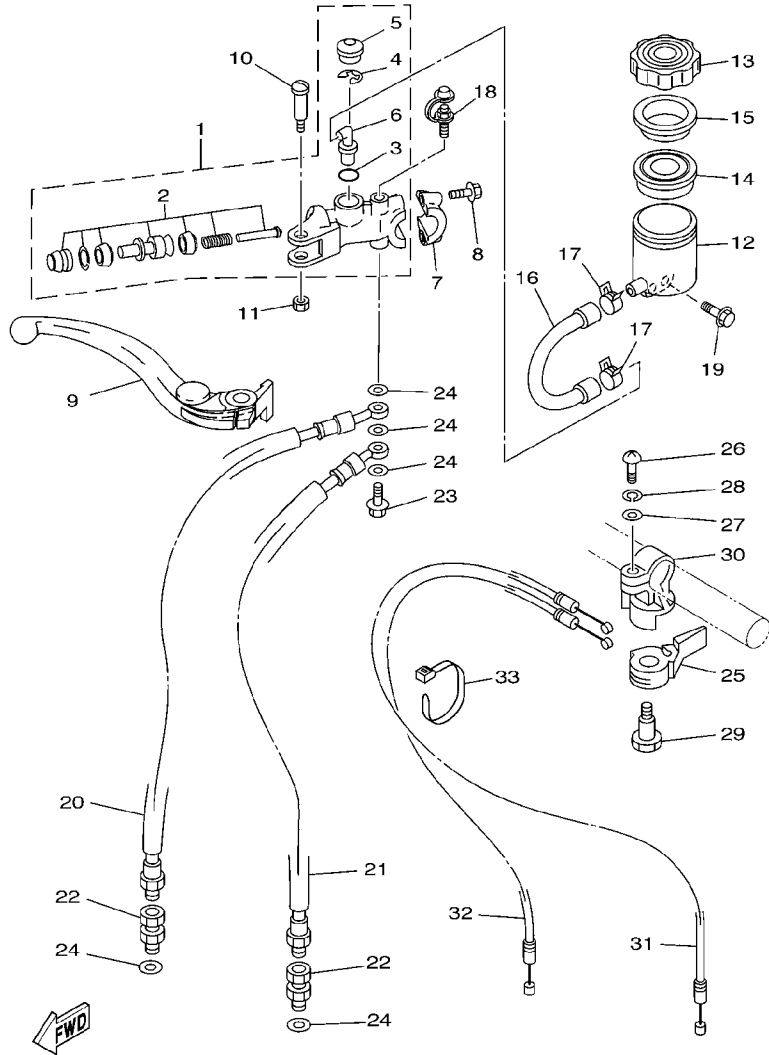

5KE2100-1271

FIG. 27 FRONT MASTER CYLINDER

REF NO.	PART NO.	DESCRIPTION	5KE4				REMARKS
1	5KE-W2587-00	MASTER CYLINDER SUB ASSY	1				
2	5KE-W0041-00	.CYLINDER KIT, MASTER	1				
3	93210-15620	.O-RING	1				
4	2VN-25886-00	.CIRCLIP	1				
5	3FV-2589A-00	.COVER, DUST	1				
6	2VN-2582A-50	.JOINT	1				
7	56A-25867-00	BRACKET, MASTER CYLINDER	1				
8	5EB-26332-00	BOLT	2				
9	5KE-83922-10	LEVER 2	1				
10	3FV-2589F-00	BOLT, LEVER	1				
11	95606-06100	NUT, U	1				
12	3FV-25894-00	TANK, RESERVOIR	1				
13	3GM-25852-50	CAP, RESERVOIR	1				
14	3FV-25854-00	DIAPHRAGM, RESERVOIR	1				
15	2J2-25855-50	BUSH,DIAPHRAGM	1				
16	5KE-25895-00	HOSE, RESERVOIR	1				
17	3PA-24356-00	CLIP, PIPE 1	2				
18	1UY-W0048-50	BLEED SCREW KIT	1				
19	95027-06014	BOLT, FLANGE	1				
20	5KE-25872-10	HOSE, BRAKE 1	1				
21	5KE-25873-10	HOSE, BRAKE 2	1				
22	3LC-25885-00	JOINT	2				
23	90401-10160	BOLT, UNION	1				
24	90201-10118	WASHER, PLATE	5				
25	240-83941-00	LEVER, STARTER	1				
26	98507-06018	SCREW,PAN HEAD	1				
27	90201-12175	WASHER, PLATE	1				

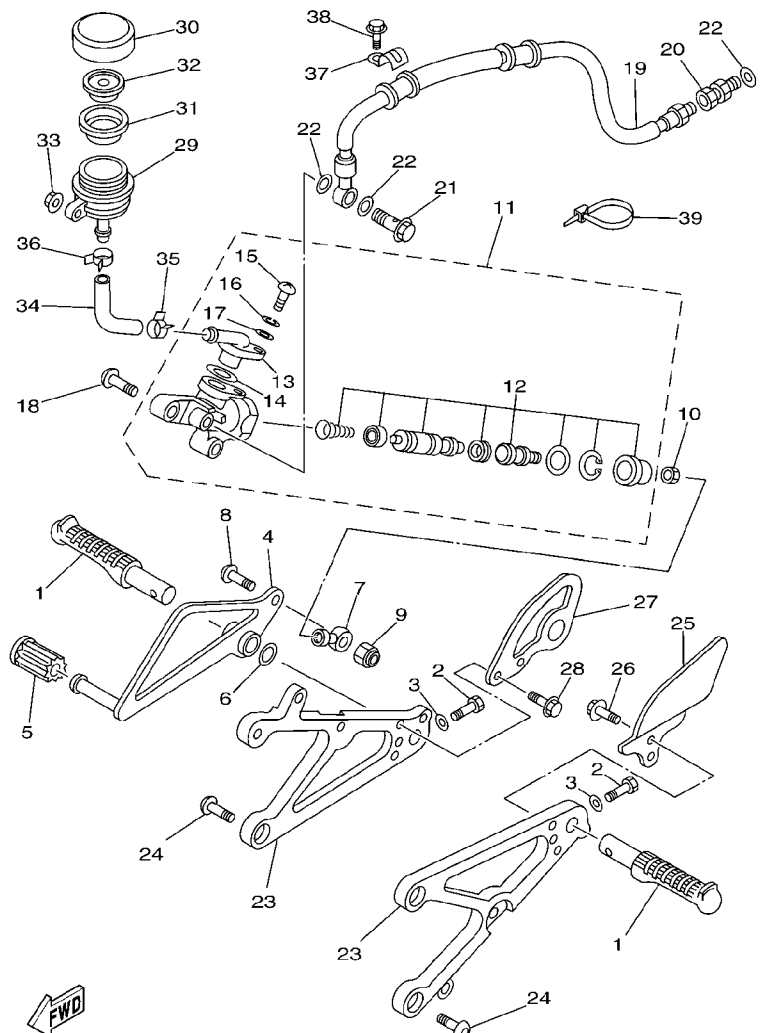

5KE1100-0280

FIG. 28 STAND. FOOTREST

REF NO.	PART NO.	DESCRIPTION	5KE4				REMARKS
1	4JT-27411-20	FOOTREST 1	2				
2	97007-06020	BOLT	2				
3	92907-06600	WASHER, PLATE	2				
4	5KE-27211-00	PEDAL, BRAKE	1				
5	4A0-18113-00	COVER, SHIFT PEDAL	1				
6	90201-14212	WASHER, PLATE	1				
7	8CW-18156-00	JOINT 1	1				
8	92017-06020	BOLT, BUTTON HEAD	1				
9	95607-06100	NUT, U	1				
10	95307-06600	NUT	1				
11	3YL-2583V-00	RR. MASTER CYLINDER ASSY.	1				
12	3YL-W0042-50	.CYLINDER KIT, MASTER	1				
13	36Y-2582A-50	JOINT	1				
14	93210-15620	.O-RING	1				
15	98511-04012	.SCREW, PAN HEAD	1				
16	92902-04100	.WASHER, SPRING	1				
17	92901-04600	.WASHER, PLATE	1				
18	92017-08025	BOLT, BUTTON HEAD	2				
19	4TW-25874-00	HOSE, BRAKE	1				
20	3LC-25885-00	JOINT	1				
21	90401-10168	BOLT, UNION	1				
22	90201-10118	WASHER, PLATE	3				
23	4JT-27412-20	BRACKET, FOOTREST 1	2				
24	92017-08020	BOLT, BUTTON HEAD	4				
25	4TW-27445-00	PLATE 1	1				
26	90119-05239	BOLT, WITH WASHER	2				
27	4TW-27264-00	BRACKET 2	1				

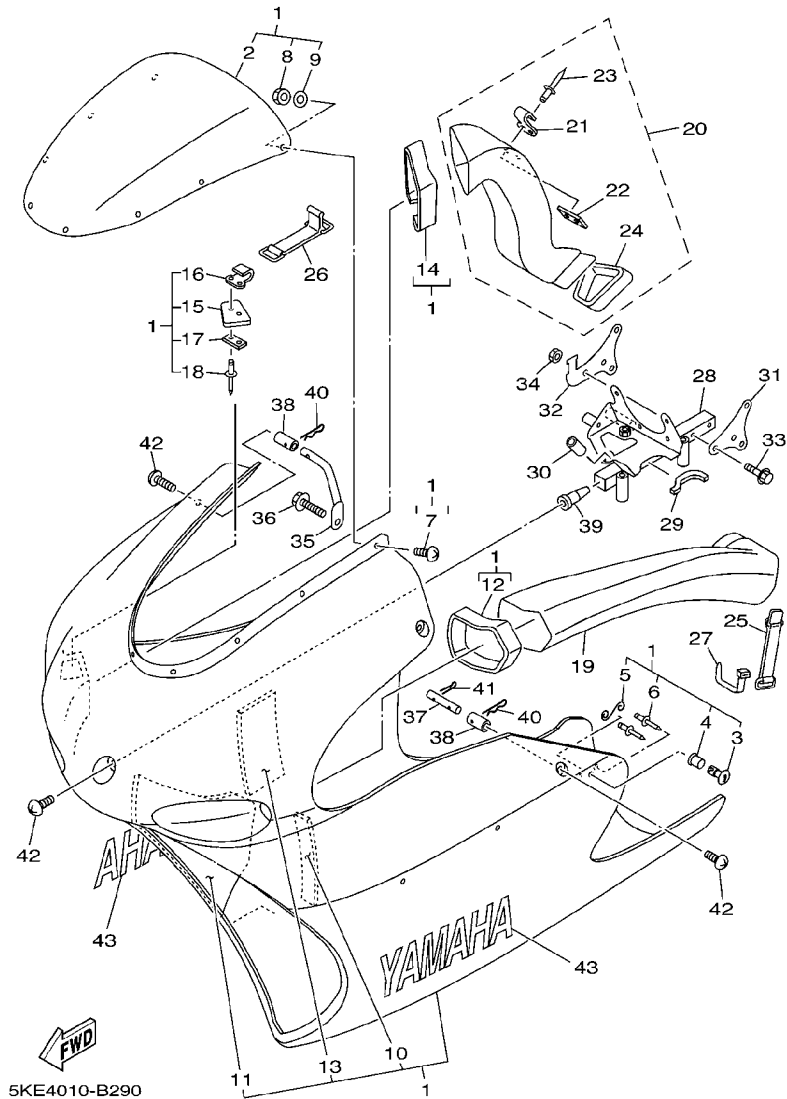
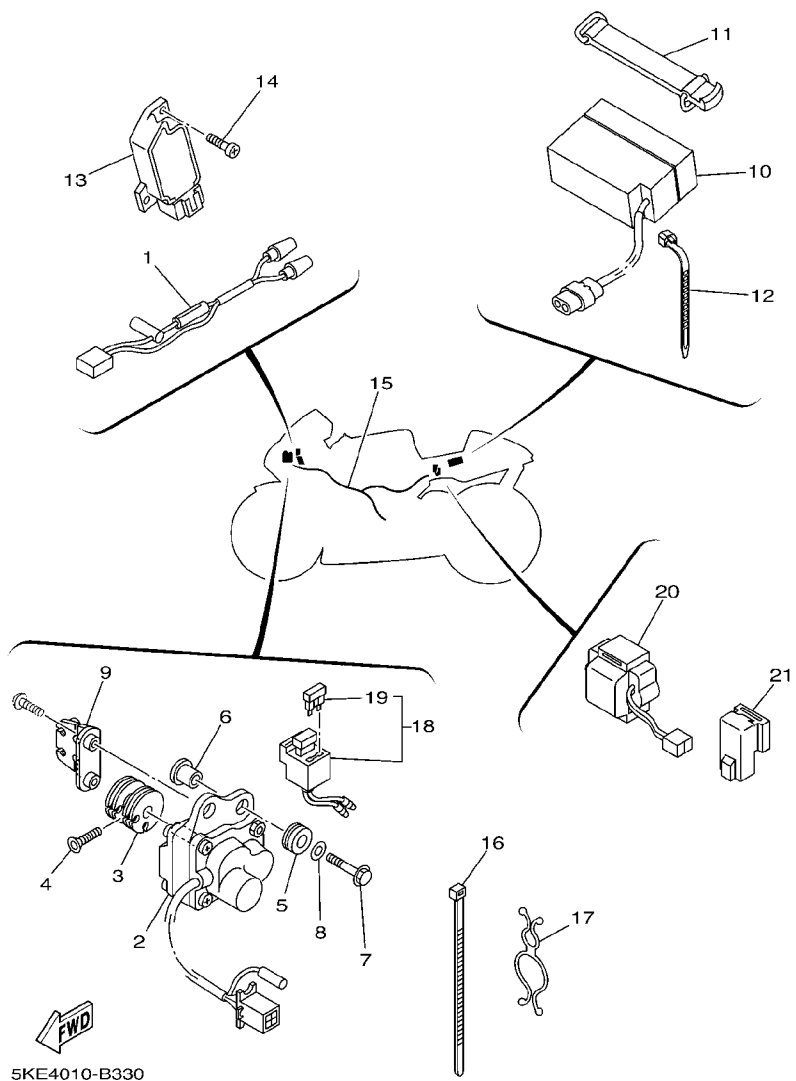

FIG. 29 COWLING 1

REF NO.	PART NO.	DESCRIPTION	5KE4				REMARKS
1	5KE-28350-10	COWLING ASSY	1				
2	5KE-28381-00	.WINDSHIELD	1				
3	3YL-28386-00	.HEAD	5				
4	240-28389-00	.RIVET	5				
5	3YL-28388-00	.SPRING	5				
6	90267-32103	.RIVET, BLIND	10				
7	98907-04010	.SCREW, BIND	8				
8	95607-04100	.NUT, U	8				
9	92907-04200	.WASHER	8				
10	5KE-21638-00	.DAMPER 1	1				
11	5KE-28372-00	.DAMPER	1				
12	4TW-28371-00	.DAMPER	1				
13	3Y6-21747-00	.DAMPER	1				
14	5KE-28371-00	.DAMPER	1				
15	5KE-28336-00	.PLATE	1				
16	4TW-2175R-00	.HOOK BAND	1				
17	4TW-2175L-00	.PLATE, LOCK	1				
18	90267-30189	.RIVET, BLIND	2				
19	5KE-2838N-00	DUCT 1	1				
20	5KE-2838R-00	DUCT 2	1				
21	4TW-2175R-00	.HOOK BAND	1				
22	4TW-2175L-00	.PLATE, LOCK	1				
23	90267-30189	.RIVET, BLIND	2				
24	5KE-28371-10	.DAMPER	1				
25	18G-82131-00	BAND, BATTERY	1				
26	3TJ-82131-00	BAND, BATTERY	1				
27	90465-10098	CLAMP	1				

FIG. 33 ELECTRICAL 1



REF NO.	PART NO.	DESCRIPTION	5KE4				REMARKS
1	4TW-82117-00	WIRE, LEAD	1				
2	3LC-85850-00	GEARED MOTOR COMP.	1				
3	5KE-85821-00	PULLEY, DRIVE	1				
4	90151-05031	SCREW, COUNTERSUNK	1				
5	90480-14023	GROMMET	2				
6	90387-063E6	COLLAR	2				
7	95027-06025	BOLT, FLANGE	2				
8	90201-06380	WASHER, PLATE	2				
9	5KE-85824-00	BRACKET, CABLE	1				
10	4TW-82100-00	BATTERY ASSY (GS PE12V0.8)	1				
11	18G-82131-00	BAND, BATTERY	1				
12	90464-13077	CLAMP	1				
13	1JK-81960-A1	RECTIFIER & REGULATOR ASSY	1				
14	98507-06020	SCREW, PAN HEAD	2				
15	5KE-82590-20	WIRE HARNESS ASSY	1				
16	90465-13275	CLAMP	2				
17	90464-26114	CLAMP	2				
18	4HF-82150-00	FUSE HOLDER ASSY	1				
19	42X-82151-00	FUSE (10A-BL)	2				
20	4TW-82576-00	EMERGENCY STOP SWITCH ASSY	1				
21	1UY-81950-92	RELAY ASSY	1				

NUMERICAL INDEX

PART NO.	REF. NO.	PART NO.	REF. NO.	PART NO.	REF. NO.	PART NO.	REF. NO.	PART NO.	REF. NO.	PART NO.	REF. NO.
5KE-11111-10	1 - 1	3XV-13613-01	7 - 10	353-14186-00	8 - 9	4DP-17221-12	12 - 19	5KE-21510-00	22 - 11	3YL-23141-00	19 - 11
5KE-11311-10	1 - 7	2KM-13614-00	7 - 3	4PE-14194-00	8 - 4	5KE-17231-10	12 - 20	5KE-21552-20	18 - 19		19 - 27
5KE-1131D-10	1 - 15		7 - 11	4TW-14197-00	8 - 26	5KE-17241-10	12 - 21	5KE-2160A-02	7 - 20	4TW-23142-10	19 - 12
5KE-1131F-00	1 - 21	3YL-13617-00	7 - 4	830-14231-11	8 - 14	3YL-17251-30	12 - 22	50M-21638-00	15 - 40		19 - 28
5KE-1131M-00	1 - 10		7 - 12	830-14231-12	8 - 14	5KE-17261-30	12 - 23	5KE-21638-00	29 - 10	3JD-23145-LD	19 - 4
5KE-1131W-00	1 - 25	5KE-13620-00	7 - 9	830-14231-13	8 - 14	5KE-17411-30	12 - 1	5KE-2171V-00	15 - 6		19 - 20
5KE-1131X-00	1 - 20	5KE-13621-01	7 - 7	8J0-14251-00	8 - 27	5KE-17421-00	12 - 16	3Y6-21747-00	29 - 13	36Y-23146-10	19 - 3
5KE-1132D-10	1 - 16	5KE-13622-00	7 - 15	5KE-14261-00	8 - 3	278-17424-01	2 - 6	5KE-21747-00	15 - 37		19 - 19
5KE-1132E-00	1 - 28	4NK-13907-00	20 - 33	1FN-14565-00	8 - 7	3AK-17471-00	12 - 30	3YL-21751-00	15 - 26	3SP-23147-MD	19 - 15
5KE-1133E-00	1 - 34	5KE-14101-30	8 - 1	5KE-14610-21	9 - 1	5KE-18101-00	14 - 1	4TW-2175L-00	7 - 27		19 - 31
4TW-1133F-00	1 - 35	5KE-14102-30	8 - 2	5KE-14620-00	9 - 2	4DP-18110-00	14 - 16		7 - 33	26H-23156-00	19 - 5
4TW-1133G-01	1 - 36	3JD-14104-00	8 - 6	5KE-1469A-00	9 - 11	4DP-18112-00	14 - 7		29 - 17		19 - 21
5KE-1133H-00	1 - 37	4TW-14107-17	8 - 10	5KE-14753-10	9 - 10	3FV-18113-00	14 - 17		29 - 22	2K8-23158-LD	19 - 8
5KE-1134E-00	1 - 17	4TW-1410A-00	8 - 5	4DP-14755-00	9 - 13	4A0-18113-00	28 - 5	5KE-2175L-00	7 - 30		19 - 24
5KE-11351-20	1 - 38	5KE-1410H-00	8 - 13	5KE-1490J-30	8 - 18	5KE-18115-00	14 - 9	4TW-2175R-00	7 - 23	5KE-23170-10	19 - 7
5KE-11351-30	1 - 38	5KE-14112-60	8 - 22	5KE-15100-02	10 - 1	3TC-18116-00	14 - 12		29 - 16		19 - 23
5KE-11351-40	1 - 38	5ET-14115-00	8 - 17	5KE-15131-00	10 - 24	3TC-18117-00	14 - 13		29 - 21	3LC-23181-00	19 - 9
5KE-11351-50	1 - 38	4TW-14131-00	8 - 12	4A0-15363-00	10 - 17	3XV-18122-00	13 - 6	4TW-2176X-00	7 - 31		19 - 25
5KE-11354-00	1 - 11	5KE-14141-R9	8 - 19	5KE-15381-00	12 - 4	3MA-18127-00	14 - 4	4TW-22110-02	16 - 1	5KE-2331W-00	18 - 9
5KE-11400-10	2 - 1	5KE-14141-S0	8 - 19	4JT-15381-01	3 - 5	3XV-18140-00	13 - 18	1X2-22127-00-20	16 - 7	4TW-23340-21	19 - 33
5KE-11455-00	3 - 1	5KE-14141-S1	8 - 19		12 - 27	3CW-18156-00	28 - 7	3FV-22128-00	16 - 11	4TW-23357-10	19 - 10
5KE-11531-00	3 - 7	5KE-14141-S2	8 - 19	5KE-15411-00	10 - 11	5KE-18172-00	13 - 11	3MA-22141-01	16 - 12		19 - 26
5KE-11536-00	2 - 12	5KE-14141-S3	8 - 19	5KE-15421-00	10 - 14	3XV-18173-00	13 - 7	4TW-22147-00	16 - 27	1J7-23415-00	18 - 3
4JT-11611-11	2 - 8	5KE-14141-S4	8 - 19	3YL-15441-00	11 - 35	3XJ-18178-00	13 - 13	4TW-22151-00	15 - 32	4TW-23435-01	19 - 35
5KE-11631-20-A0	2 - 7	5KE-14141-S5	8 - 19	5KE-15451-00	10 - 12	3YL-18182-00	13 - 8	4JT-2216F-10	16 - 2	5KE-23490-10	18 - 8
5KE-11631-20-B0	2 - 7	4KM-14142-25	8 - 20	5KE-15461-00	10 - 23	3YL-18184-00	13 - 9	5KE-2217A-00	16 - 15	5KE-23495-10	18 - 16
5KE-11631-20-C0	2 - 7	4KM-14142-30	8 - 20	5KE-16111-00	2 - 13	3YL-18185-00	13 - 5	5KE-2217F-00	16 - 22	5KE-24110-00-36	20 - 1
4XM-11633-01	2 - 9	4KM-14142-35	8 - 20	5KE-16151-00	11 - 2	5KE-18511-00	13 - 22	3XV-22184-00	16 - 6	5KE-2411B-00	20 - 2
5KE-11932-00	1 - 31	137-14143-70	8 - 21	5F7-16153-00	11 - 15	5KE-18512-00	13 - 23	4TW-22187-10	16 - 4	4JT-2411M-00	20 - 31
5KE-11932-10	1 - 32	137-14143-72	8 - 21	3YL-16154-00	11 - 13	5KE-18513-00	13 - 24	5KE-22210-10	17 - 1	4JT-2411R-00	20 - 34
3YL-12232-00	5 - 9	137-14143-74	8 - 21	5F7-16181-00	11 - 12	3XV-18531-00	13 - 25	4JT-22219-00	17 - 6	4DP-24181-00	20 - 27
5KE-12422-01	4 - 7	137-14143-76	8 - 21	5KE-16310-00	11 - 3	5KE-18535-00	13 - 26	4JT-22239-00	17 - 7	3LC-24182-00	20 - 28
5KE-12428-00	4 - 8	137-14143-78	8 - 21	3AK-16321-00	11 - 9	5KE-18541-00	13 - 1	1RK-22251-00	17 - 8	5KE-24311-00	20 - 3
5KE-12450-00	4 - 1	137-14143-80	8 - 21	3YL-16321-01	11 - 8	3XV-18562-00	13 - 3		18 - 6	5KE-24312-10	20 - 4
4TW-12461-01	5 - 1	137-14143-82	8 - 21	168-16324-00	11 - 7	5KE-21110-01	15 - 10	3AK-22252-00	17 - 10	5KE-24313-00	20 - 5
22W-12462-00	5 - 2	137-14143-84	8 - 21	5F7-16343-00	11 - 20	4JT-21118-00	15 - 17	4AA-22259-50	17 - 2	3PA-24356-00	27 - 17
5KE-12482-00	5 - 11	137-14143-86	8 - 21	26J-16351-00	11 - 6	4TW-2117A-01	15 - 34	5KE-23102-20	19 - 1	69J-24378-00	20 - 6
5KE-12483-00	5 - 12	137-14143-88	8 - 21	59W-16356-00	11 - 18	4TW-21190-02	15 - 3	5KE-23103-20	19 - 17	3XJ-24380-00	20 - 23
5KE-12484-00	5 - 13	137-14143-90	8 - 21	5KE-16357-00	11 - 28	5KE-2119T-10	15 - 18	5KE-23110-20	19 - 6	3CV-24491-10	20 - 9
5KE-13161-00	6 - 12	137-14143-92	8 - 21	3R4-16371-01	11 - 5	5KE-21240-10	7 - 22	4TW-23111-10	19 - 14	4JT-24500-00	20 - 14
5HO-13310-00	6 - 2	137-14143-94	8 - 21	5KE-16381-00	11 - 29	4TW-21249-01	7 - 28		19 - 30	4X8-24512-00	20 - 17
5KE-13316-00	6 - 1	137-14143-96	8 - 21	3XV-16384-00	11 - 32	5KE-2134T-00	15 - 9	4TW-23118-10	19 - 13	3AJ-24523-00	20 - 18
4DP-13324-00	11 - 1	137-14143-98	8 - 21	4DP-17121-12	12 - 6	5KE-2134V-00	15 - 24		19 - 22	3AJ-24534-00	20 - 15
5KE-13411-00	6 - 10	2K6-14147-00	8 - 16	5KE-17131-30	12 - 7	5KE-2139V-00	15 - 38	5KE-23120-20	19 - 22	4JT-24611-00	20 - 21
5KE-13555-00	7 - 8	5ET-14147-00	8 - 24	5F7-17136-00	12 - 24	5KE-21411-00	15 - 13	5KE-23128-00	19 - 16	4JT-24612-00	20 - 22
5KE-13565-00	7 - 16	137-1414K-00	8 - 21	3YL-17151-30	12 - 8	5KE-21419-00	15 - 14		19 - 32	5KE-24710-10	21 - 1
5KE-13610-00	7 - 1	4TW-1416A-00	8 - 23	5KE-17161-30	12 - 9	4DP-21495-00	15 - 41	5KE-23136-00	19 - 2	5KE-24713-00	21 - 2
3XV-13613-01	7 - 2	5ET-14185-00	8 - 15	5KE-17211-30	12 - 17	4JT-21495-10	15 - 22		19 - 18	4JT-24763-00	21 - 3

NUMERICAL INDEX

PART NO.	REF. NO.	PART NO.	REF. NO.	PART NO.	REF. NO.	PART NO.	REF. NO.	PART NO.	REF. NO.	PART NO.	REF. NO.	PART NO.	REF. NO.
4TW-25117-00	22 - 3	3LC-25885-00	28 - 20	5KE-28371-10	29 - 24	4TW-W0047-10	23 - 5	90151-06001	12 - 5	90201-225A4	18 - 7		
4TW-25168-00	22 - 1	3FV-25894-00	27 - 12	5KE-28372-00	29 - 11		23 - 16		12 - 28	90201-253K0	12 - 10		
4DP-25181-10	22 - 8	4EW-25894-00	28 - 29	5KE-28381-00	29 - 2	3LC-W0047-50	25 - 3	90157-05004	13 - 4	90201-25526	18 - 4		
4TW-25183-00	22 - 4	4TW-25895-00	28 - 34	3YL-28386-00	29 - 3	1UY-W0048-50	23 - 9	90159-06016	11 - 11	90201-256E4	12 - 11		
4DP-2518A-00	24 - 4	5KE-25895-00	27 - 16	3YL-28388-00	29 - 5		23 - 20	90170-06228	14 - 10	90201-256E6	12 - 10		
4TW-25317-00	24 - 3	3FV-2589A-00	27 - 5	240-28389-00	29 - 4		25 - 7	90170-14171	3 - 10	90202-05193	20 - 20		
5KE-25338-00	24 - 1	3FV-2589F-00	27 - 10	5KE-2838N-00	29 - 19		27 - 18	90170-20255	11 - 17	90202-08022	9 - 8		
3YL-25364-00	24 - 14	5KE-25919-00	23 - 7	5KE-2838R-00	29 - 20	4DP-W0057-00	25 - 2	90179-10696	15 - 23	90209-22082	12 - 24		
5KE-25366-10	24 - 7		23 - 18	1UY-81950-92	33 - 21	4TW-W0057-00	23 - 2	90179-12248	30 - 2	90215-14204	3 - 9		
5KE-25376-00	24 - 11	5KE-25919-50	25 - 8	1JK-81960-A1	33 - 13		23 - 13	90179-20255	12 - 35	90215-20212	11 - 16		
4DP-25379-00	24 - 20	4JT-25924-00	25 - 5	4TW-82100-00	33 - 10	4TW-W0057-10	23 - 4	90179-25033	18 - 5	90215-21121	12 - 34		
4TW-25381-00	24 - 22	5KE-25924-00	23 - 8	4TW-82117-00	33 - 1		23 - 15	90185-08097	9 - 9	90267-30189	7 - 24		
4TW-25383-00	24 - 10		23 - 19	1KT-82122-00	15 - 36	5KE-W2587-00	27 - 1		24 - 15		7 - 32		
5KE-25384-00	24 - 9	3YL-26121-00	26 - 1	18G-82131-00	7 - 25	4DP-Y1332-00	6 - 3		24 - 21		29 - 18		
4TW-25388-01	24 - 18	3YL-26122-01	26 - 2		29 - 25	90101-10709	16 - 18	90185-18104	16 - 13		29 - 23		
4TW-25389-01	24 - 19	47X-26241-00	26 - 5		33 - 11		16 - 20		22 - 10	90267-32018	15 - 39		
4TW-25398-00	22 - 7	47X-26242-00	26 - 6	3TJ-82131-00	29 - 26		16 - 24		24 - 23	90267-32103	29 - 6		
	24 - 12	3YL-26243-00	26 - 7	4HF-82150-00	33 - 18		17 - 3	90201-06043	30 - 5	90267-40114	7 - 29		
5KE-25435-10	24 - 13	4JT-26246-00	26 - 3	42X-82151-00	33 - 19	90105-10300	15 - 21	90201-06380	33 - 8	90267-48147	9 - 12		
5KE-25436-10	24 - 13	3Y1-26249-00	26 - 8	3YL-82310-00	30 - 7	90105-10445	2 - 15	90201-06571	5 - 8	90280-04001	2 - 3		
5KE-25437-10	24 - 13	3YL-26281-01	26 - 9	3YL-82320-01	30 - 8	90109-06028	10 - 26	90201-08027	1 - 19	90338-06041	10 - 15		
5KE-25438-10	24 - 13	3YL-26282-00	26 - 10	4PE-82370-10	30 - 10	90109-06029	10 - 27	90201-08028	1 - 19		15 - 11		
5KE-25439-10	24 - 13	5KE-26311-00	26 - 12	4TW-82576-00	33 - 20	90109-06799	32 - 4	90201-08029	1 - 19	90338-18266	15 - 43		
5KE-25440-10	24 - 13	5KE-26312-00	26 - 13	5KE-82590-20	33 - 15	90109-067E6	15 - 31	90201-08030	1 - 19	90340-12144	10 - 20		
5KE-2580T-00	23 - 1	4DP-26331-00	27 - 31	5F6-82911-00	32 - 1	90109-08398	27 - 29	90201-08032	1 - 19	90340-18101	10 - 6		
5KE-2580U-00	23 - 12	5EB-26332-00	27 - 8	4V4-82913-00	32 - 2	90109-083G4	25 - 12	90201-08033	1 - 19	90383-12013	14 - 5		
4TW-2580W-01	25 - 1	4DP-26334-01	27 - 32	4A0-83522-00	31 - 8	90109-084F1	10 - 8	90201-08512	6 - 8	90387-063E6	5 - 5		
5KE-25818-00	23 - 11	5KE-26335-00	26 - 15	5KE-83540-01	31 - 1	90109-084F7	18 - 13	90201-087F0	14 - 18		33 - 6		
	23 - 22	5F6-26368-00	26 - 17	4A0-83541-00	31 - 2	90109-087F6	14 - 15	90201-08M12	18 - 14	90387-066N1	5 - 4		
4TW-25819-00	25 - 10	5KE-27211-00	28 - 4	5KE-83553-00	31 - 5	90110-08193	23 - 24	90201-10118	27 - 24	90387-06737	20 - 12		
4JT-2581T-00	23 - 23	4TW-27264-00	28 - 27	5KE-83591-10	31 - 3	90111-06023	22 - 12		28 - 22	90387-081F5	20 - 30		
2VN-2582A-50	27 - 6	4JT-27411-20	28 - 1	5KE-83611-00	31 - 6	90116-06466	1 - 8	90201-10144	2 - 14	90387-084Y3	9 - 7		
36Y-2582A-50	28 - 13	4JT-27412-20	28 - 23	214-83912-00	32 - 3	90116-08104	1 - 39	90201-12166	4 - 5	90387-124Y8	16 - 17		
4TW-2582W-00	25 - 11	36Y-27414-00	15 - 2	5KE-83922-10	27 - 9	90116-08564	1 - 40	90201-12175	27 - 27		16 - 23		
3YL-2583V-00	28 - 11	4TW-27445-00	28 - 25	240-83941-00	27 - 25	90119-05239	15 - 33	90201-12588	14 - 20	90387-127V3	13 - 14		
3GM-25852-50	27 - 13	5KE-28321-00	29 - 35	240-83946-00	27 - 30		28 - 26	90201-127E1	6 - 9	90387-176R1	3 - 8		
3XP-25852-50	28 - 30	4DP-28334-00	29 - 40	4TW-83976-00	32 - 7		28 - 28		13 - 20	90387-25001	12 - 32		
2VN-25854-00	28 - 31	5KE-28336-00	29 - 15	5KE-85501-30	30 - 1	90119-06096	20 - 11		30 - 3	90401-10160	27 - 23		
3FV-25854-00	27 - 14	5KE-28345-10	29 - 29	5KE-85821-00	33 - 3	90119-06227	16 - 26	90201-127J6	17 - 5	90401-10168	28 - 21		
2VN-25855-00	28 - 32	5KE-28350-10	29 - 1	5KE-85824-00	33 - 9	90119-06228	16 - 5	90201-14212	28 - 6	90430-06166	1 - 14		
2J2-25855-50	27 - 15	5KE-28356-01	29 - 28	3LC-85850-00	33 - 2	90123-06007	26 - 14	90201-154E8	13 - 17		4 - 12		
2VN-25866-00	27 - 4	3YL-28358-00	29 - 37	5KE-W0041-00	27 - 2	90149-05245	1 - 18	90201-177G4	13 - 16		10 - 16		
56A-25867-00	27 - 7	4DP-28362-01	29 - 39	3YL-W0042-50	28 - 12	90149-06011	20 - 19	90201-183E1	22 - 9		15 - 12		
5KE-25872-10	27 - 20	4A0-28364-00	29 - 38	5KE-W0045-00	23 - 6	90150-06021	18 - 20		24 - 24	90430-08020	31 - 4		
5KE-25873-10	27 - 21	4DP-2836A-00	29 - 31		23 - 17		29 - 42	90201-183H2	10 - 7	90430-12202	10 - 19		
4TW-25874-00	28 - 19	4TW-2836E-00	29 - 32	4TW-W0046-00	25 - 4	90150-06036	21 - 5	90201-20276	12 - 13	90445-09304	5 - 10		
3XV-25876-00	28 - 37	4TW-28371-00	29 - 12	4TW-W0047-00	23 - 3	90151-05031	33 - 4		12 - 14	90445-093H5	10 - 5		
3LC-25885-00	27 - 22	5KE-28371-00	29 - 14		23 - 14	90151-06001	3 - 6	90201-206E5	12 - 14	90446-17346	29 - 30		

NUMERICAL INDEX

PART NO.	REF. NO.	PART NO.	REF. NO.	PART NO.	REF. NO.	PART NO.	REF. NO.	PART NO.	REF. NO.	PART NO.	REF. NO.
90450-40009	5 - 15	91317-05012	12 - 31	93210-06001	6 - 13	93606-12019	10 - 21	95827-06025	15 - 4		
90460-20190	5 - 14	91317-05020	26 - 11	93210-07435	1 - 26	93834-14178	12 - 33	95827-06045	15 - 5		
90460-52210	7 - 19	91317-05025	6 - 6	93210-09165	11 - 19	93834-15079	12 - 33	95827-08035	18 - 17		
90464-12089	15 - 28	91317-06020	10 - 22	93210-11453	1 - 27	93834-16104	12 - 33	95827-10045	15 - 15		
	28 - 39		15 - 7	93210-15620	27 - 3	93900-00031	22 - 6	95827-10060	15 - 16		
90464-13077	33 - 12		18 - 18		28 - 14		24 - 6	97007-05020	32 - 6		
90464-16115	26 - 16	91317-06025	4 - 10	93210-19758	10 - 3	94112-1713L	22 - 5	97007-06020	28 - 2		
90464-18246	15 - 29		7 - 17	93210-21190	10 - 18	94116-1713M	24 - 5	97017-06020	14 - 8		
90464-26114	33 - 17		10 - 13	93210-22164	11 - 25	94561-62110	24 - 16	97027-06020	9 - 14		
90465-10098	29 - 27		26 - 4	93210-28543	10 - 4	94561-62114	24 - 16	97780-40110	31 - 7		
90465-13152	15 - 30	91317-06030	10 - 9	93210-34001	1 - 23	94661-62031	24 - 17	97801-03008	20 - 16		
	20 - 26	91317-06040	16 - 3	93210-42482	11 - 26	94709-00374	1 - 5	98507-03006	7 - 5		
	27 - 33	91317-08035	19 - 36	93210-42728	9 - 3	95027-06012	11 - 36		7 - 13		
90465-13275	15 - 27	91317-10016	17 - 9	93210-63556	1 - 2		15 - 25	98507-04008	8 - 8		
	20 - 29	91318-06014	13 - 12	93210-88696	1 - 3		15 - 35	98507-04014	8 - 11		
	33 - 16	91380-06025	4 - 11	93300-68821	1 - 22	95027-06014	27 - 19		32 - 8		
90467-09006	20 - 7	91401-16012	25 - 6	93306-00442	12 - 3		29 - 36	98507-05008	26 - 18		
90467-10008	20 - 8	91401-25030	29 - 41	93306-00521	22 - 2	95027-06016	28 - 38	98507-05014	8 - 25		
90467-11044	28 - 36	91A20-05004	20 - 24		24 - 2	95027-06020	30 - 6	98507-06010	6 - 11		
90467-14057	28 - 35	91A20-05065	20 - 25	93306-20470	12 - 26		30 - 9	98507-06018	27 - 26		
90468-10050	23 - 10	92017-06020	28 - 8	93306-20526	12 - 2	95027-06025	33 - 7	98507-06020	33 - 14		
	23 - 21	92017-08020	25 - 9	93306-20574	12 - 25	95027-06030	5 - 6	98511-04012	28 - 15		
	20 - 13		28 - 24	93306-30316	3 - 4		29 - 33	98580-06020	30 - 4		
90480-13163	21 - 6	92017-08025	28 - 18	93306-30572	2 - 2	95027-08020	15 - 20	98907-04010	29 - 7		
90480-13197	33 - 5	92901-04600	28 - 17	93306-90109	4 - 2	95027-08030	9 - 5	98907-05008	20 - 10		
90480-14023	15 - 44	92902-04100	28 - 16	93306-90302	13 - 2	95304-06700	14 - 11	98907-05012	1 - 24		
90480-14153	17 - 11	92907-03100	7 - 6	93306-90601	24 - 8	95307-06600	11 - 23	98907-05020	1 - 12		
	15 - 45		7 - 14	93310-22057	12 - 18		15 - 8	99009-12400	4 - 6		
90480-14585	5 - 3	92907-04200	29 - 9	93310-31510	2 - 10		28 - 10		13 - 21		
90480-15363	15 - 42	92907-05100	26 - 19	93310-332J5	11 - 14	95307-08700	15 - 10	99009-17400	13 - 15		
90480-18276	20 - 32	92907-05600	6 - 7	93311-32261	3 - 3	95606-06100	27 - 11	99009-20400	12 - 15		
90480-18525	9 - 6	92907-06100	27 - 28	93315-11206	11 - 30	95607-04100	29 - 8	99247-00100	21 - 4		
90480-20389	7 - 21	92907-06200	1 - 29	93315-42523	16 - 9	95607-06100	14 - 14	99247-00280	29 - 43		
90480-25482	7 - 26		11 - 22	93320-21507	16 - 10		28 - 9	99510-10114	1 - 42		
	13 - 10	92907-06600	9 - 15		16 - 16		32 - 5	99530-10014	10 - 2		
90501-052G5	11 - 10		28 - 3	93332-00001	18 - 1	95607-06200	5 - 7		10 - 25		
90501-230A5	9 - 4	92907-18200	16 - 14	93332-00081	18 - 2		28 - 33				
90506-20007	11 - 33	93101-12126	4 - 4	93342-22516	16 - 8	95607-08100	18 - 15				
90508-121A2	13 - 19	93101-56095	11 - 27	93399-999T7	18 - 10	95607-10200	15 - 19				
90508-231A5	14 - 3	93102-12224	11 - 31	93420-30049	3 - 2		16 - 19				
90508-29742	14 - 19	93102-25438	2 - 4	93440-25084	12 - 12		16 - 21				
90560-12075	14 - 2	93102-30243	11 - 4	93450-16068	2 - 11		16 - 25				
90560-12361	18 - 11	93102-32337	12 - 29	93450-21053	18 - 12		17 - 4				
91314-06016	7 - 18	93102-35030	2 - 5	93515-32029	11 - 24	95617-06100	29 - 34				
91314-06020	10 - 10	93109-11073	4 - 3	93603-12030	6 - 4	95707-06500	1 - 9				
91314-06035	19 - 34	93109-12012	14 - 6	93604-08071	1 - 6		1 - 30				
91314-08035	1 - 33	93210-04279	11 - 21	93604-10011	4 - 9	95707-08500	1 - 41				
91317-05010	11 - 34	93210-06001	1 - 4		6 - 5	95827-06010	1 - 13				